

 **COMFORTline**
Symfonie **COMPACT BOX**

ASSEMBLY MANUAL

BOX 7

4 segments 4,5 x 10,11 x 1,0 m

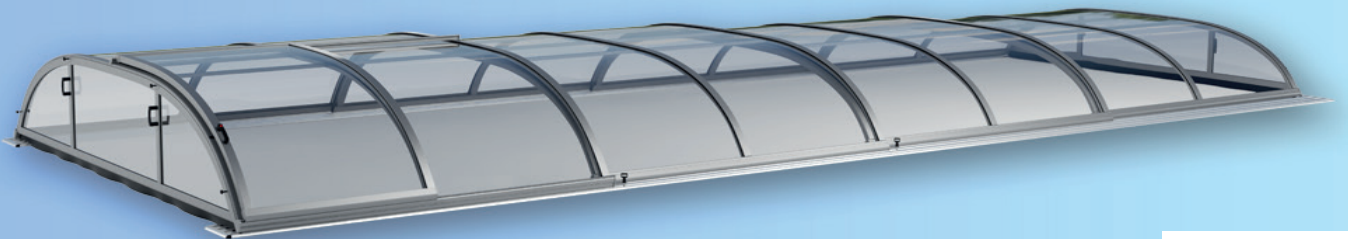

Video manual



Scan the QR code before you begin.
This will provide access to the video manual, ensuring
a smooth and accurate mounting process for the Symfonie Compact Box.

BOX

Content

1	General information	4
2	Parts list and tools	5
2.1	Fasteners	5
2.2	Seal	5
2.3	Parts	6
2.4	Plastic caps	7
2.6	Required tools list	8
2.7	Enclosed tools list	8
3	Track	9
3.1	Tracks measurements for correct installation	9
3.2	Tracks measures	10
3.3	Cross section of the track with its rails	10
3.4	Layout of the track parts	11
4	Segment 1 - Entrance variants	12
5	Segment 1	13
5.1	Segment 1 - Parts of the segment 1	13
5.2	Segment 1 - Entrance RL.45.1A - Mounting workflow	14
5.3	Segment 1 - Entrance RL.45.1B - Mounting workflow	17
5.4	Segment 1 - Entrance RL.45.1C - Mounting workflow	20
5.5	Segment 1 - Entrance RL.45.1D - Mounting workflow	23
5.6	Segment 1 - Rubber seal	26
5.7	Segment 1 - Entrance A, C	27
5.8	Segment 1 - Entrance B, D	28
6	Segments 2, 3, 4	29
6.1	Segments 2, 3, 4 - Parts of the segments 2, 3, 4	29
6.2	Segments 2, 3, 4 - Mounting workflow	30
6.3	Middle segments 2, 3 - Collectors	33
6.4	Last segment 4 - Catchers	34
7	Front and back ends	35
8	Entrance - Side sliding door	36
8.1	Entrance - Side sliding door - Parts of the side sliding door	36
8.2	Entrance - Side sliding door - Mounting workflow	37
8.3	Entrance - Side sliding door - Installation	40
9	Spare parts	41



1 General information

Before delving into the detailed installation process, let's provide some general information about Diamant-Unipool pool enclosures.

Diamant-Unipool enclosures come pre-assembled, eliminating the need for drilling. All structural and small parts required for installation are included in the box. You only need to ensure you have the correct installation tools.

For a smooth installation process, ensure proper access to the pool. At least two people are required to handle the enclosure safely. Regularly check the structure's functions during installation to promptly correct any mistakes.

Prior to assembly, verify that the pavement offers a suitable foundation for the tracks. It must be even, with no waviness or height differences exceeding 0.5cm within 1m. The surface should be horizontal, with a maximum allowance of 2cm within 1m. The pavement should be a minimum of 10cm deep, drillable, and anchorable. Check the quality and structure of the pavement for unevenness (see Fig.2.).



Fig. 1. Ideal surface for proper functioning



Fig. 2. Non-suitable surface for proper functioning - pool enclosure doesn't work

Suitable surfaces (reinforced materials):

Glued paving (tiles), concrete strips matching the track width, and well-installed wooden floors without plastic admixture.

Unsuitable surfaces (unreinforced materials):

Sand or gravel beds, block paving, wood-plastic boards, and chipped pavers.







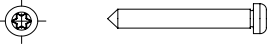
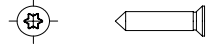

Track Installation:

Due to the thermal expansion of track materials, gaps may form in track joints. These gaps vary based on installation period and weather conditions. In spring and autumn, gaps are rare, with a tolerance of 0.01 - 0.4 cm. In summer, the tolerance is 0.01 - 0.6 cm. This natural occurrence cannot be prevented.

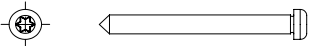
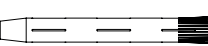
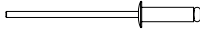
If the preparation for installation wasn't correct, tracks can become wavy, copying the surface, rendering the pool enclosure non-functional. If discovered, contact the responsible party for the surface to arrange disassembly, surface repair, and reassembly. Continued use in this condition can lead to extreme damage.

2 Parts list and tools

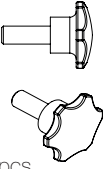
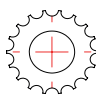
2.1 Fasteners

 <p>Diameter 6mm, length 45 mm, torex self-tapping screw</p> <p>61 pcs <u>S.01</u></p>	 <p>Diameter 6,3 mm, length 25mm, flat head torx self- tapping screw</p> <p>2 pcs <u>S.02</u></p>	 <p>M6 x 30 torx</p> <p><u>S.03</u></p>	 <p>M6 x 20 flat head torx</p> <p><u>S.04</u></p>
 <p>Diameter 6mm, length 60 mm, torex self-tapping screw</p> <p>96 pcs <u>S.05</u></p>	 <p>Wall plug</p> <p>96 pcs <u>S.10</u></p>	 <p>Aluminium rivet 4,8 - 16</p> <p>224 pcs <u>S.20</u> <u>S.20.1</u> black</p>	 <p>Aluminium rivet 4 - 10</p> <p>18 pcs <u>S.21</u> <u>S.21.1</u> black</p>
 <p>Aluminium rivet 4,8 - 10</p> <p><u>S.22</u> <u>S.22.1</u> black</p>	 <p>Aluminium rivet 4,8 - 12</p> <p>4 pcs <u>S.23</u></p>	 <p>8 pcs <u>S.06</u></p>	 <p>Screw washer</p> <p>3 pcs <u>S.07</u></p>
 <p>M5-25</p> <p>8 pcs <u>S.08</u></p>	 <p>M5-16</p> <p>6 pcs <u>S.09</u></p>		

2.2 Seal

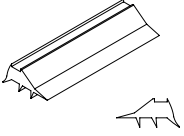
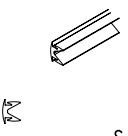
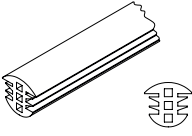
 <p><u>S.G.01</u></p>	 <p><u>S.G.02</u></p>	 <p><u>S.G.05</u></p>
----------------------------------------------------------------------------------------------------------	----------------------------------------------------------------------------------------------------------	-----------------------------------------------------------------------------------------------------------



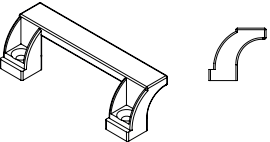
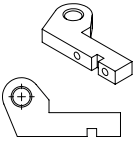
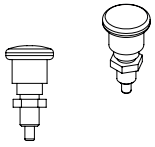
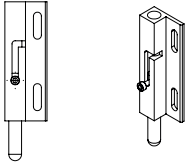
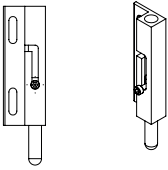
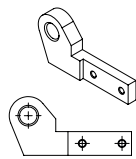
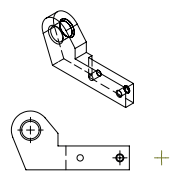
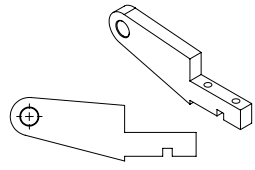
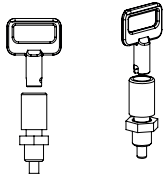
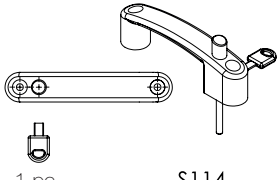
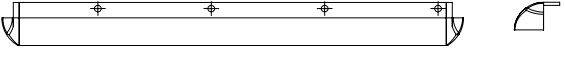
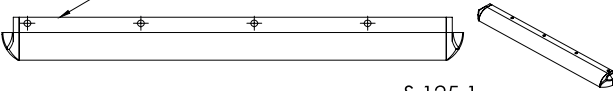
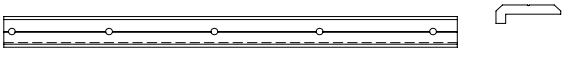
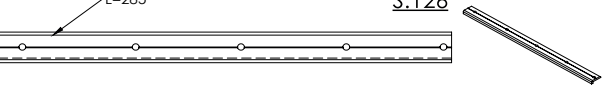

2 Parts list and tools

2.3 Parts

 <p>1 pc <u>S.109</u></p>	 <p>2 pcs <u>S.101</u></p>	 <p>2 pcs <u>S.102</u></p>	 <p> <u>S.117</u></p>
 <p> <u>S.117.1</u></p>	 <p>3 pcs <u>S.111</u></p>	 <p>3 pcs <u>S.111.1</u></p>	 <p>2 pcs <u>S.112</u></p>
 <p>5 pcs <u>S.113</u></p>	 <p>1 pc <u>S.114</u></p>		
 <p> <u>S.125</u></p>  <p> <u>S.125.1</u></p>			
 <p> <u>S.126</u></p>  <p> <u>S.126.1</u></p>			

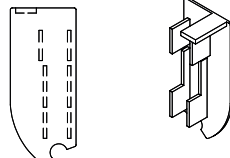
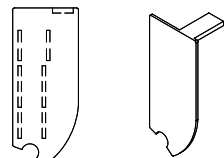
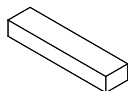
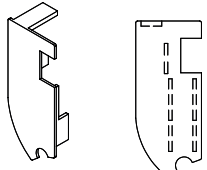
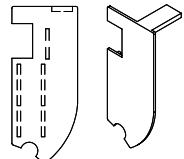
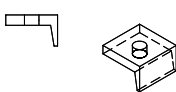
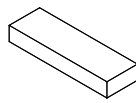
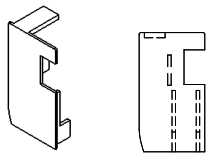
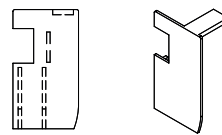
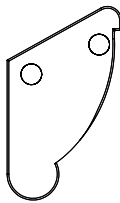
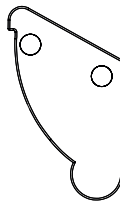
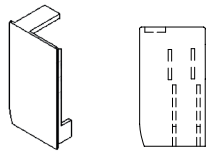
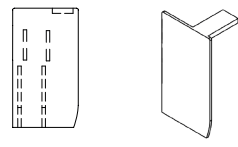
2 Parts list and tools

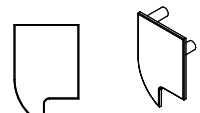
2.4 Plastic caps

 <p>98 pcs S.116 S.116.1 black</p>	 <p>6 pcs S.128</p>	 <p>6 pcs S.128.1</p>	 <p>S.131</p>
 <p>2 pcs S.118</p>	 <p>2 pcs S.118.1</p>	 <p>S.120</p>	 <p>S.124</p>
 <p>1 pc S.119</p>	 <p>1 pc S.119.1</p>	 <p>2 pcs S.122</p>	 <p>2 pcs S.122.1</p>
 <p>2 pcs S.127</p>	 <p>2 pcs S.127.1</p>	 <p>2 pcs S.123</p>	 <p>2 pcs S.123.1</p>
 <p>16 pcs S.140 black</p>			

2 Parts list and tools

2.5 Required tools list

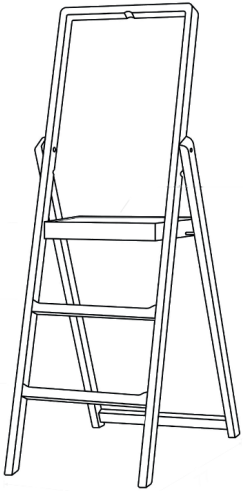

Ladder

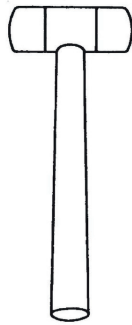

Rubber/plastic hammer

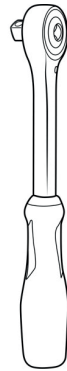

Ratchet

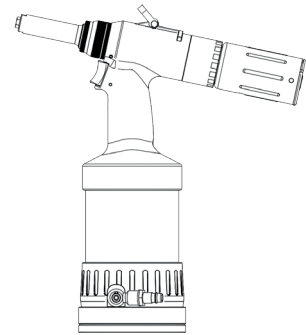

Pneumatic rivet gun

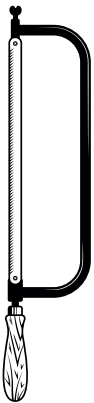

Hand saw

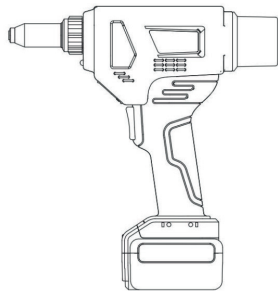

Battery-powered rivet gun

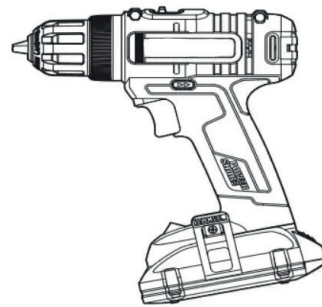

Battery-powered drill

2.6 Enclosed tools list

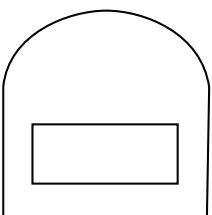

3 Track

3.1 Tracks measurements for correct installation

BIRD VIEW of the biggest segment:

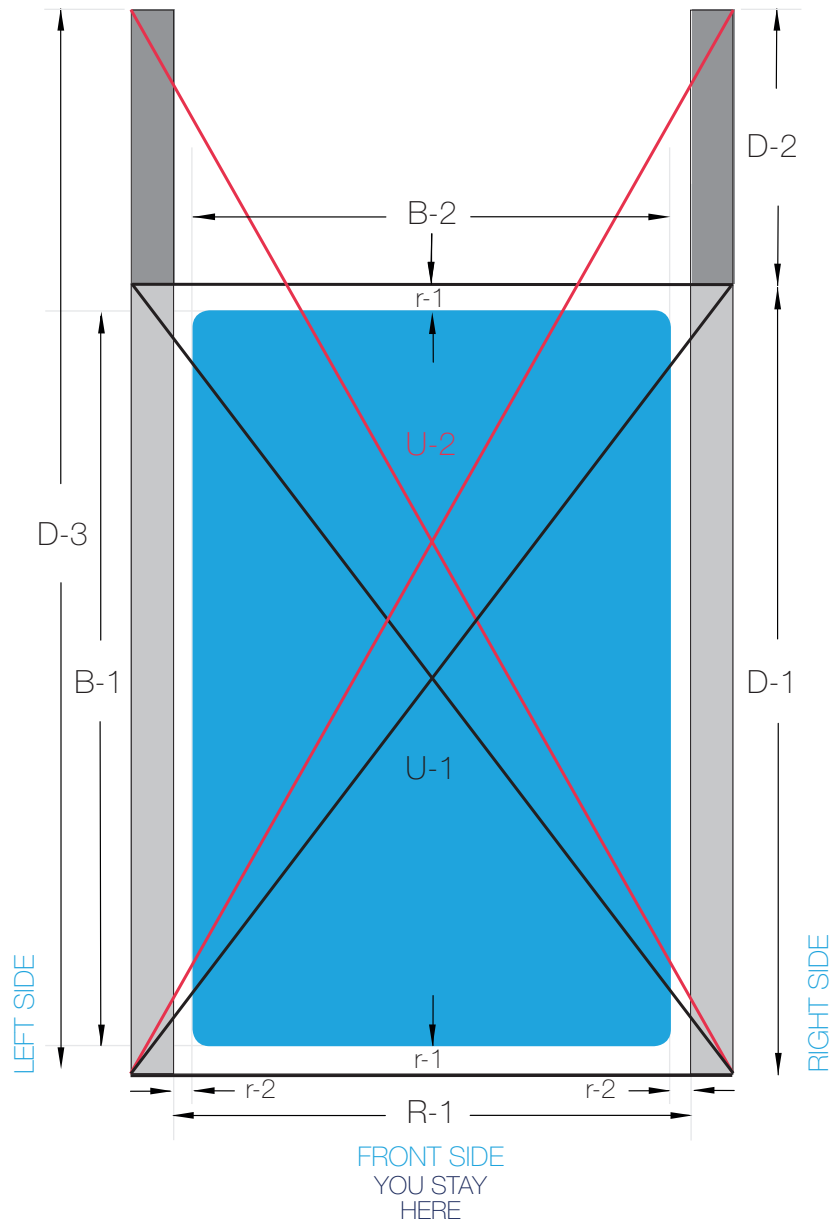
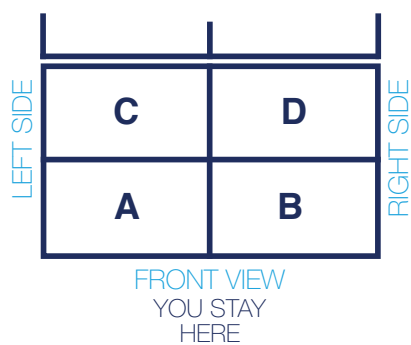

- B-1: Total length of the pool
- B-2: Total width of the pool
- D-1: Length of the track under the pool enclosure
- D-2: Length of track extension
- D-3: Total length of the track
- R-1: Inner width of the pool enclosure
- r-1: Reserve of the pool enclosure
- r-2: Reserve width of the pool enclosure
- U-1: Basic diagonal measurement
- U-2: Control diagonal measurement

3 Track

3.2 Tracks measures

BOX 7 - rail D.1011-4

Inner width 4 500 mm

Length 10 110 + 2 500 mm

4 segments

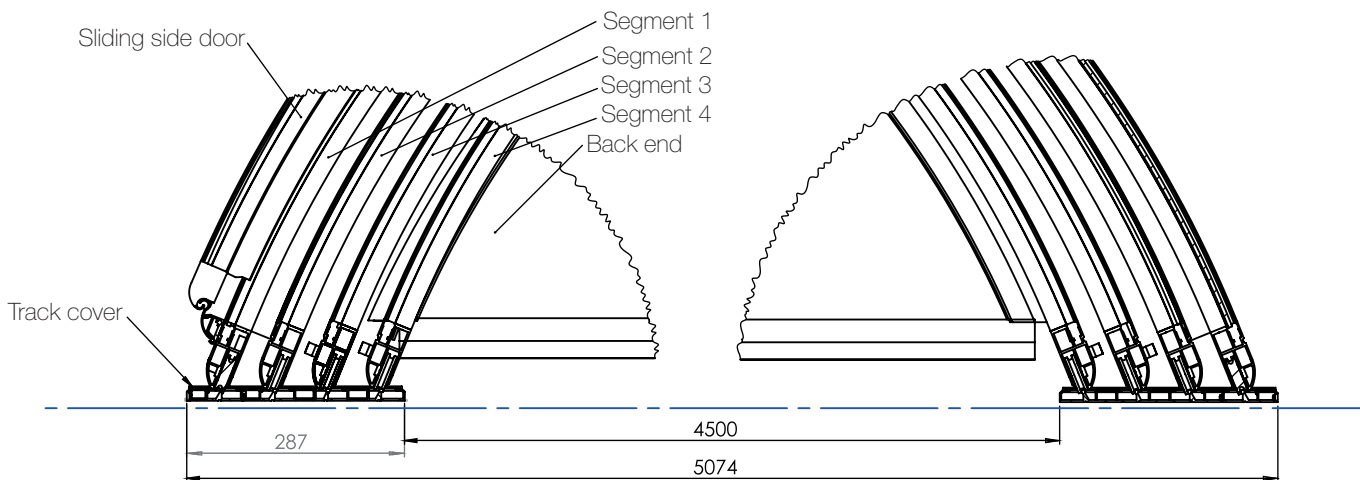
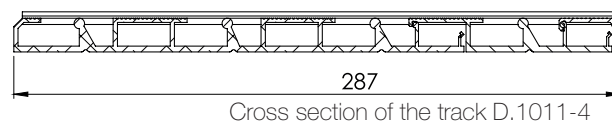
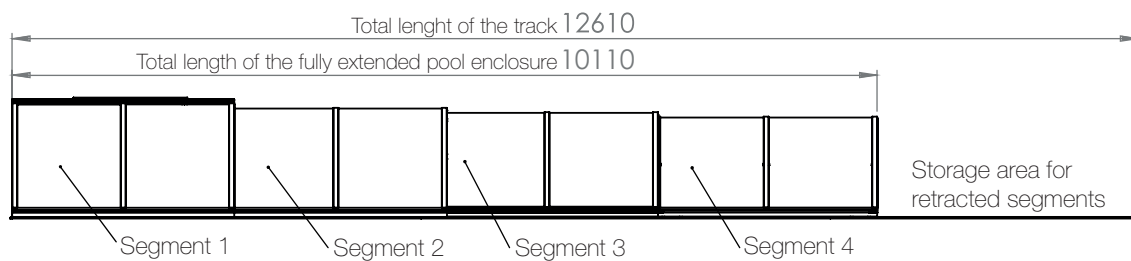

3.3 Cross section of the track with its rails

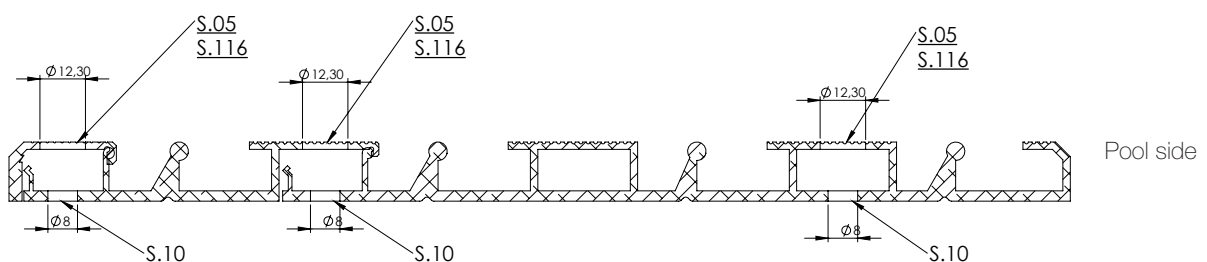

3 Track

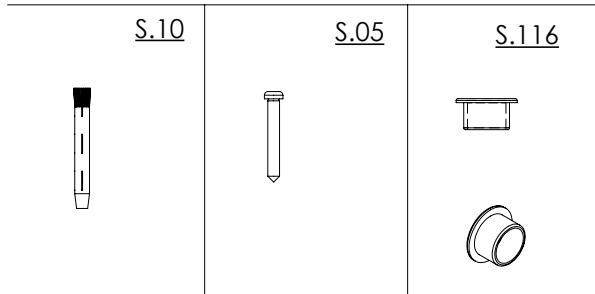

NOTE
 The holes in the track are pre-drilled. If necessary, holes can be drilled at a different spacing. In that case always drill the holes according to the pattern (holes already drilled).

3.4 Layout of the track parts

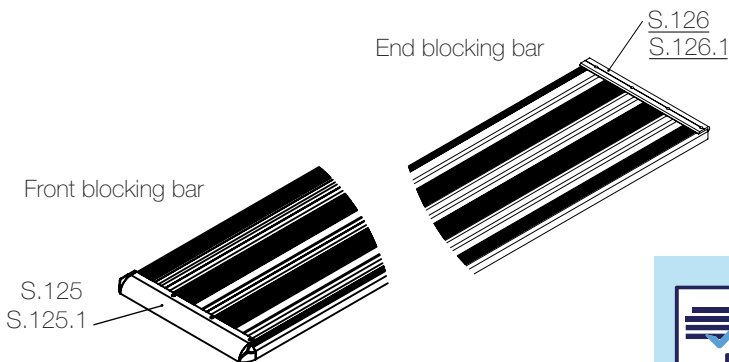
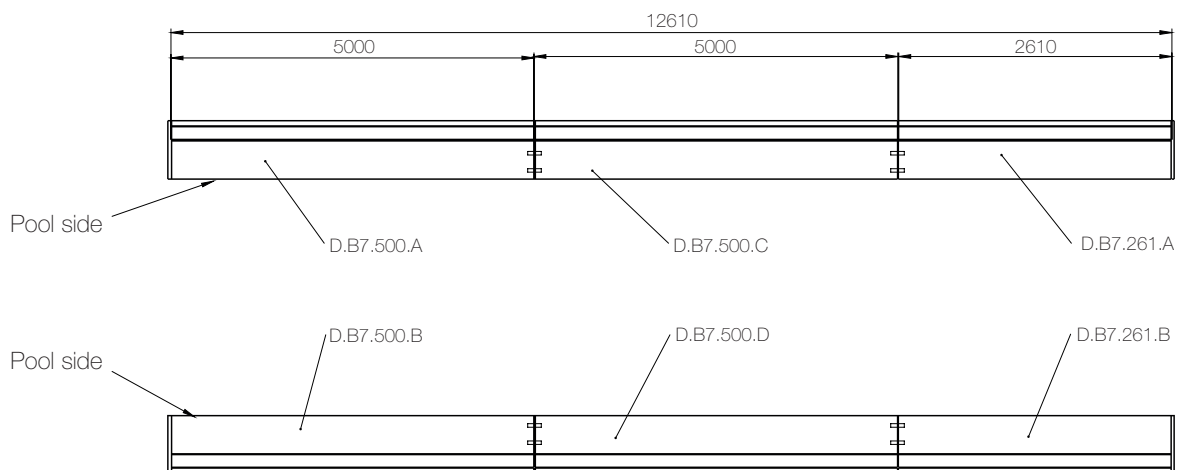

Rivet with S.21 when segments are on

Rivet with S.21 when segments are on

NOTE
 The front blocking bar S.125 must always be mounted at the front view where the largest segment is placed. The end blocking bar S.126 should be mounted at the back where is the smallest segment. The part S.126 facilitates water flow during cleaning. These bars are riveted once the pool enclosure is completed.

Description	Code	Pcs
Track, segment	D.B7.500.A; B; C; D	4
Track, segment	D.B7.261.A; B	2
Front blocking bar	S.125; S.125.1	1+1
End blocking bar	S.126; S.126.1	1+1

4 Segment 1 - Entrance variants

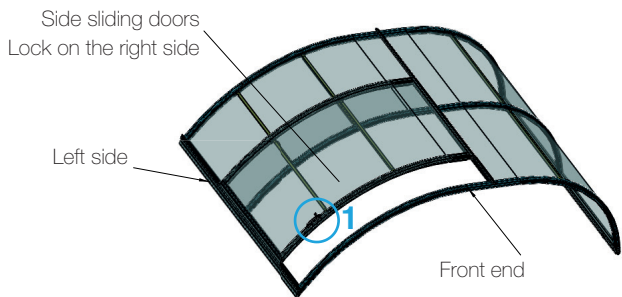

RL.45.1A

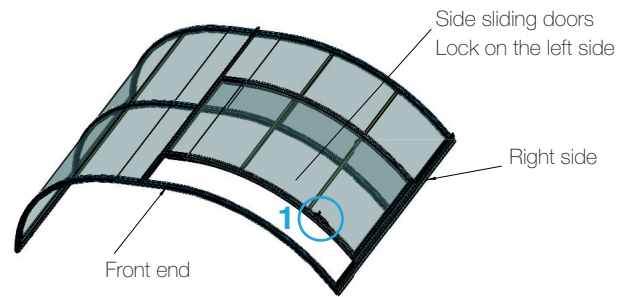

RL.45.1B

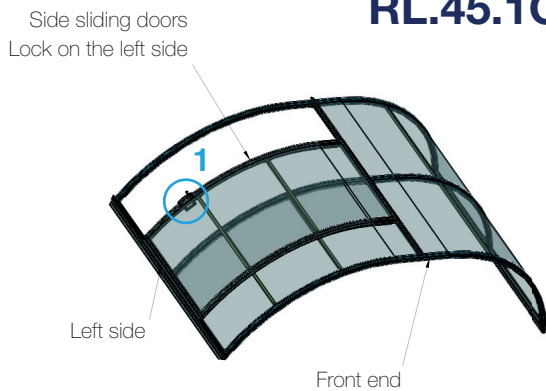

RL.45.1C

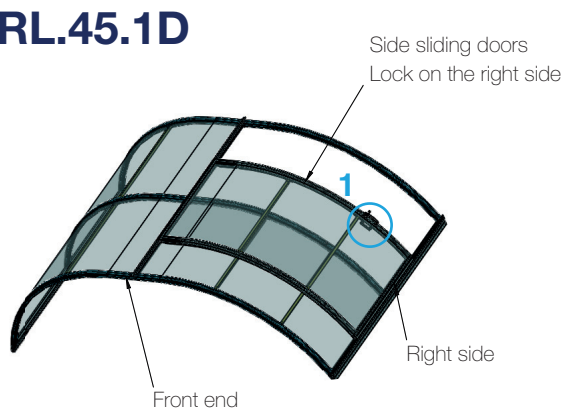

RL.45.1D

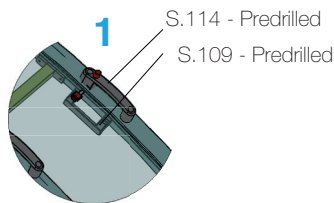

NOTE

It is essential to determine the position of the side sliding door during this assembling step. Select one of the four positions and proceed to the corresponding page marked with letters A, B, C, or D.

5 Segment 1

5.1 Parts of the segment 1

Parts of the segment	Description	Pcs
N.B7.01.P	Front arch n.1	1
N.B7.01.S	Middle arch n.2	1
N.B7.01.Z	Back arch n.3	1
A.20.257	Guide	1
A.20.257.1	Guide with the drive	1
A.04.257	Longitudinal reinforcement with the drive	1
A.03.257	Longitudinal reinforcement	10
PC.B7.BV	Polycarbonate, half arch, entrance side	1
PC.B7.01	Polycarbonate, whole arch	1
S.G.01	Rubber seal	
S.G.02	Rubber seal	
S.G.05	Rubber seal	

Fasteners	Description	Placing	Pcs
S.01	Screw	Arch/guide	12
S.20.1	Rivet	Arch/reinforcement	44

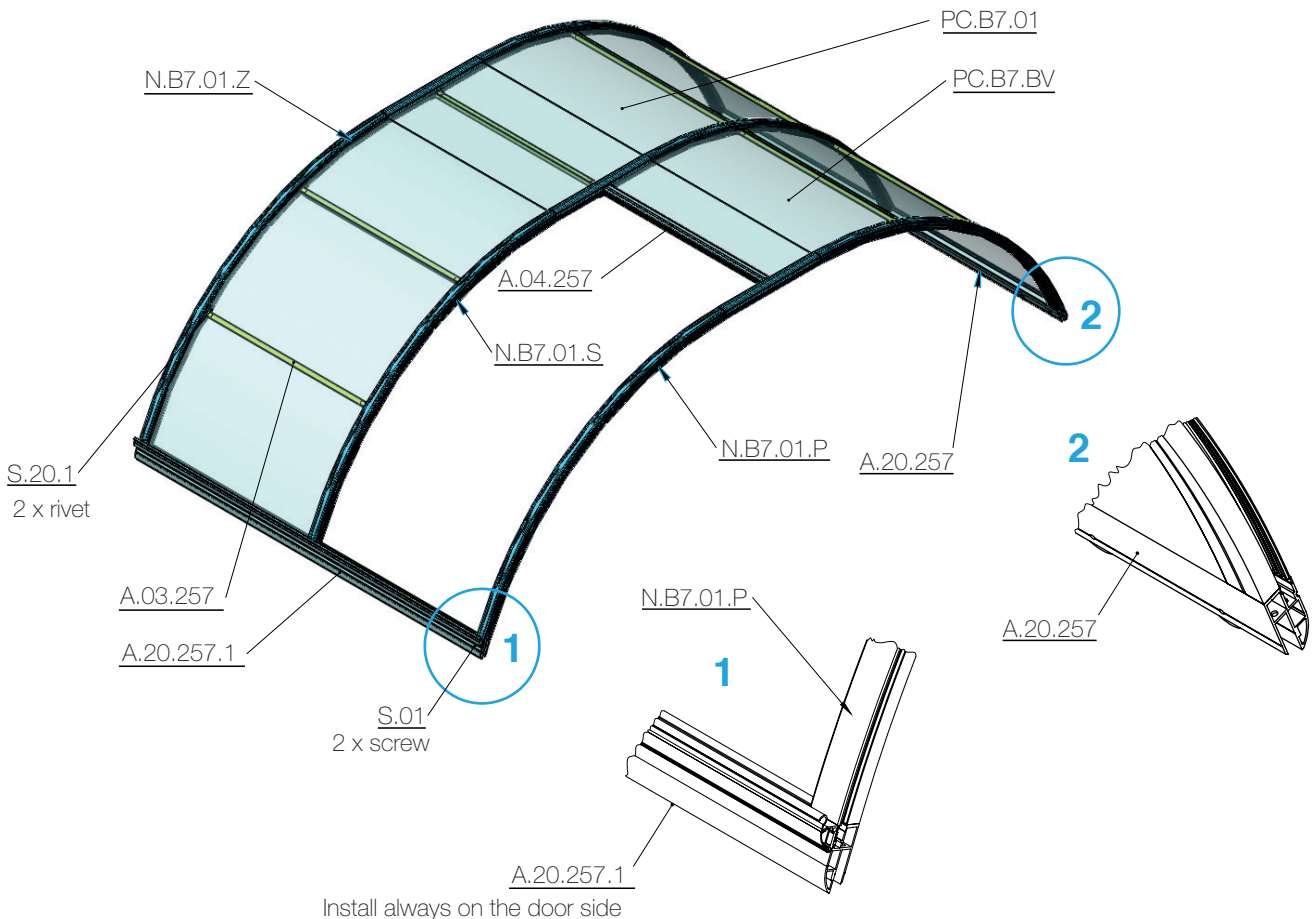
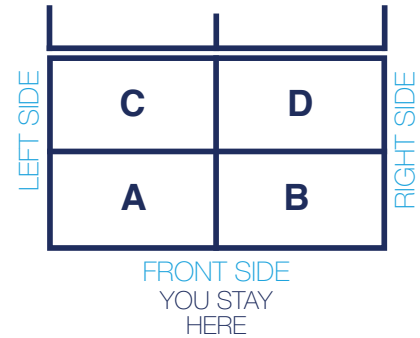

5.2 Segment 1 - Entrance RL.45.1A - Mounting workflow

1

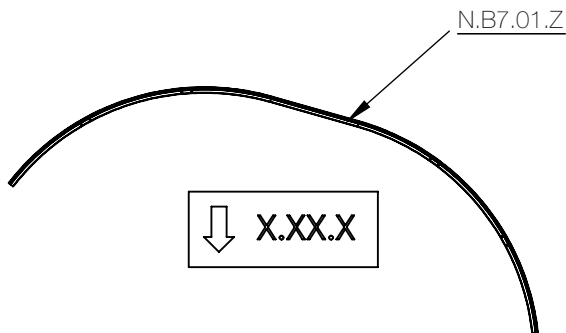

Position the back arch N.B7.01.Z on a flat surface in such a way as to avoid scratching and with the arrow pointing downwards.

2

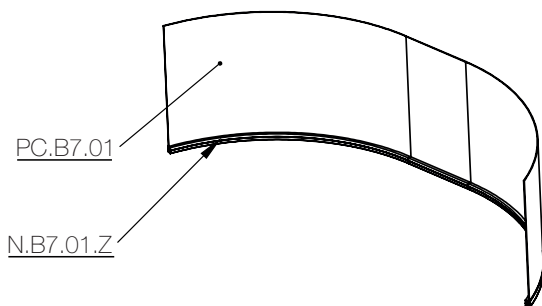

Insert polycarbonate PC.B7.01 into the arch.

3

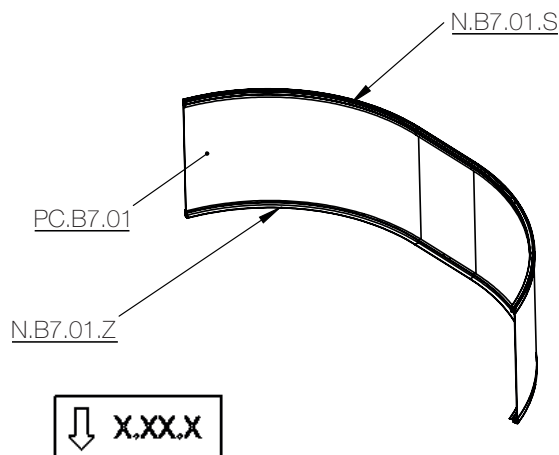

Insert the middle arch on PC.B7.01 with the arrow pointing downwards.

4

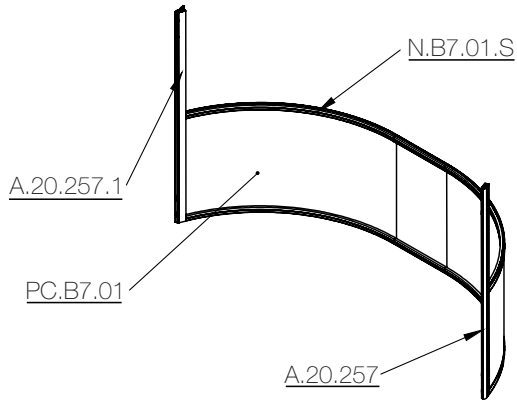

Insert the guide with the drive A.20.257.1 on the sliding door side.
Insert the guide A.20.257.
Screw all the arches together using screws S.01.

5

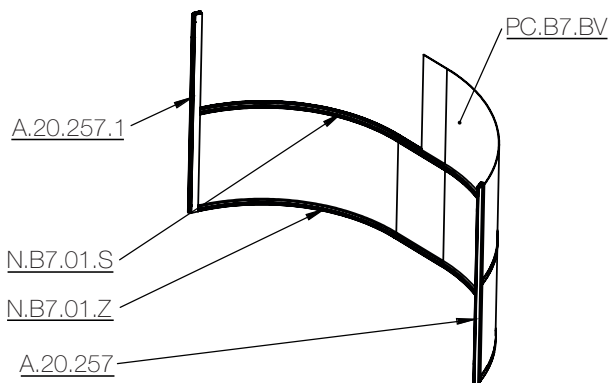

Insert PC.B7.BV correctly according to the placement of the doors.

6

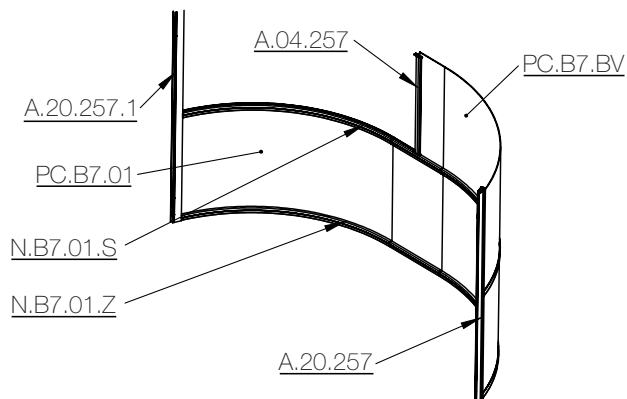

Insert longitudinal reinforcement A.04.257 with the drive and rivet with the arches.

7

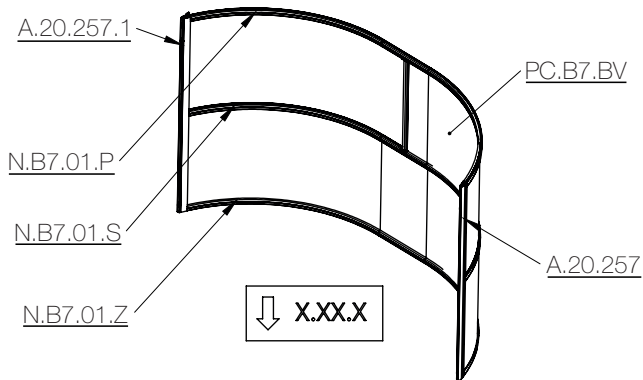

Insert the front arch N.B7.01.P with the arrow pointing downwards. Screw the arch with the guides.

8

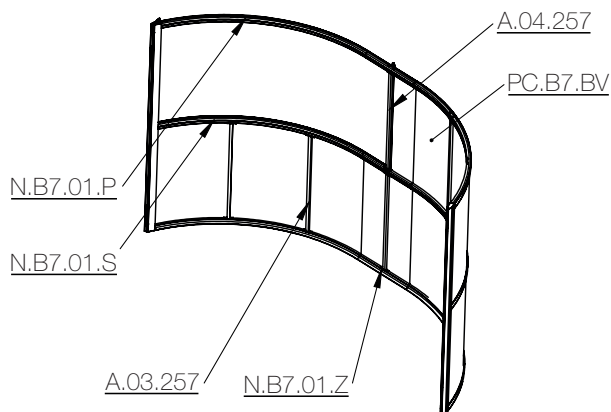

Insert longitudinal reinforcements A.03.257 and rivet them with the arches.



NOTE

The arch and guide are fastened together with S.01 screws.
Longitudinal reinforcements are riveted using S.20.1 rivets.

5.3 Segment 1 - Entrance RL.45.1B - Mounting workflow

1

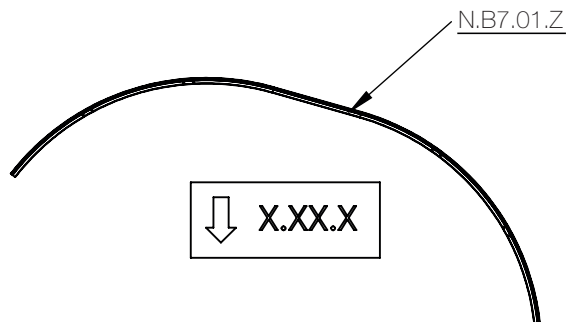

Position the back arch N.B7.01.Z on a flat surface in such a way as to avoid scratching and with the arrow pointing downwards.

2

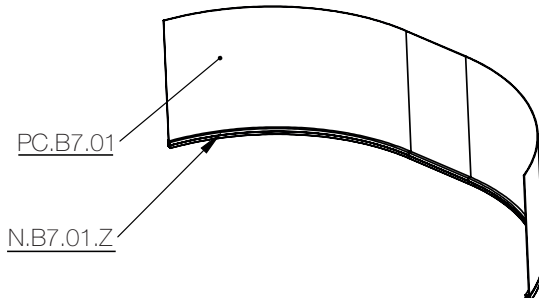

Insert polycarbonate PC.B7.01 into the arch.

3

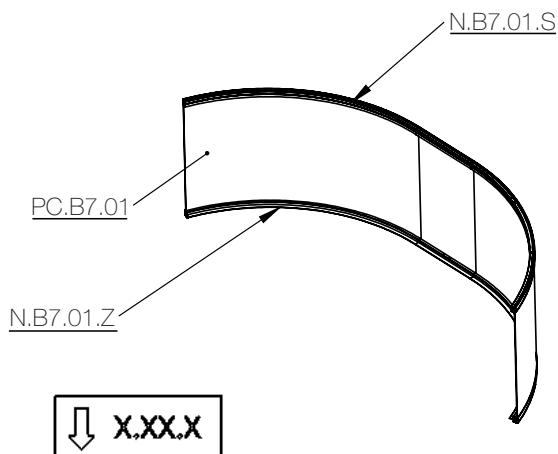

Insert the middle arch on PC.B7.01 with the arrow pointing downwards.

4

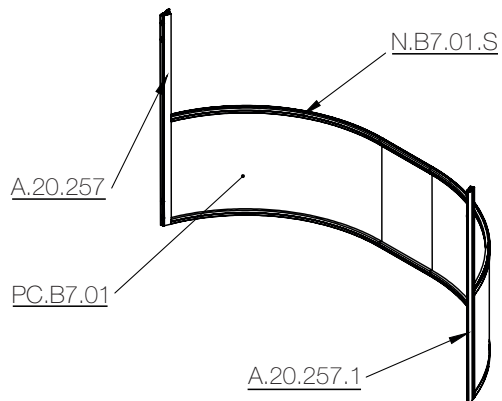

Insert the guide with the drive A.20.257.1 on the sliding door side.
Insert the guide A.20.257.
Screw all the arches together using screws S.01.

5

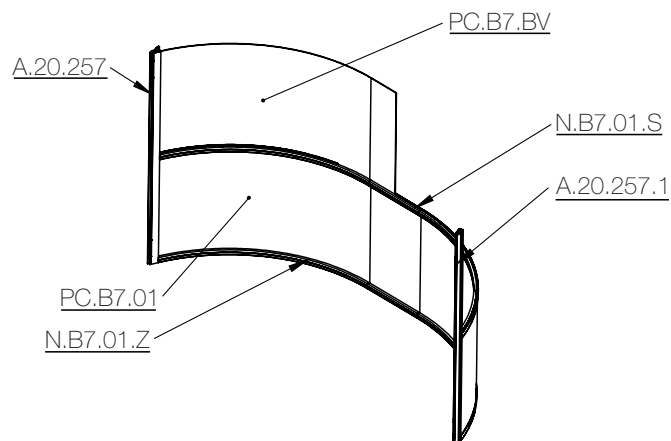

Insert PC.B7.BV correctly according to the placement of the doors.

6

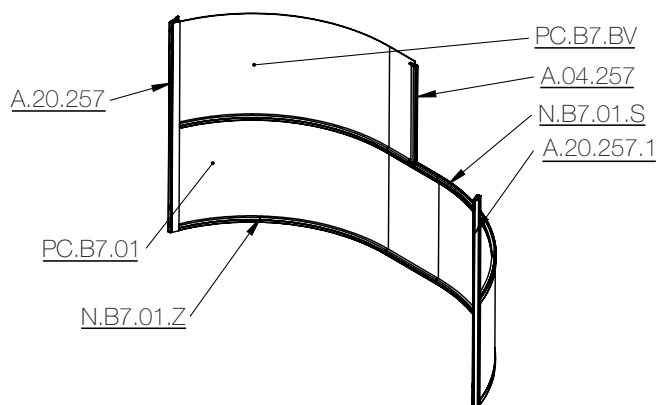

Insert longitudinal reinforcement A.04.257 with the drive and rivet with the arches.

7

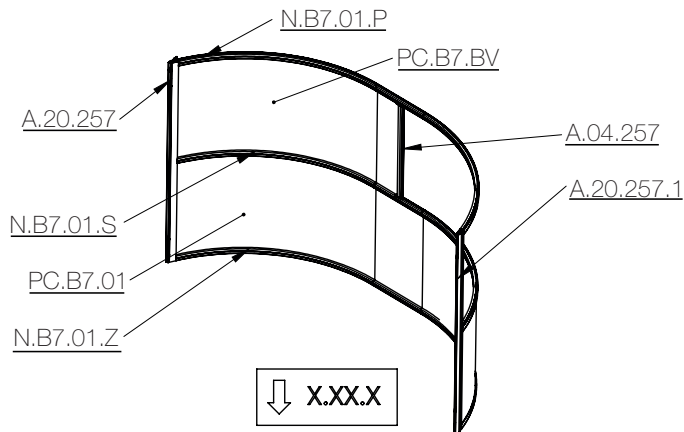

Insert the front arch N.B7.01.P with the arrow pointing downwards. Screw the arch with the guides.

8

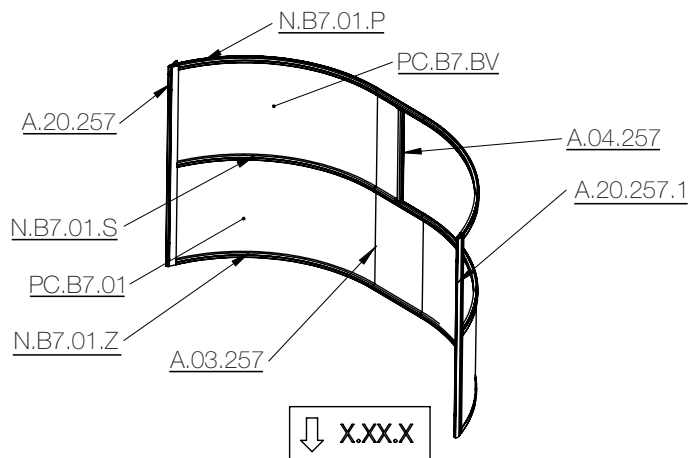

Insert longitudinal reinforcements A.03.257 and rivet them with the arches.



NOTE

The arch and guide are fastened together with S.01 screws. Longitudinal reinforcements are riveted using S.20.1 rivets.

5.4 Segment 1 - Entrance RL.45.1C - Mounting workflow

1

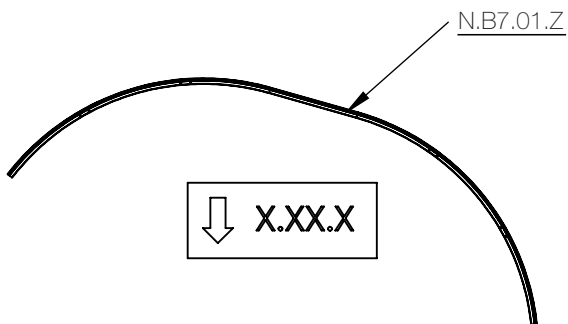

Position the back arch N.B7.01.Z on a flat surface in such a way as to avoid scratching and with the arrow pointing downwards.

2

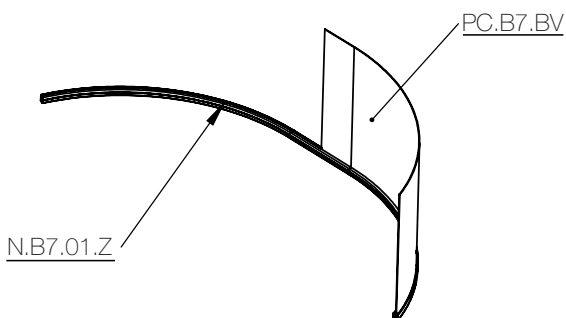

Insert polycarbonate PC.B7.BV correctly according to the placement of the doors.

3

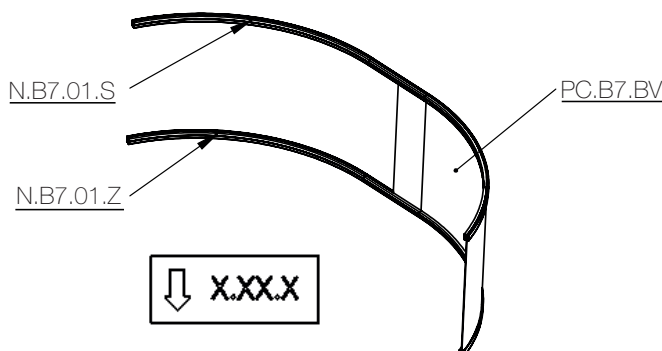

Insert the middle arch on PC.B7.BV with the arrow pointing downwards.

4

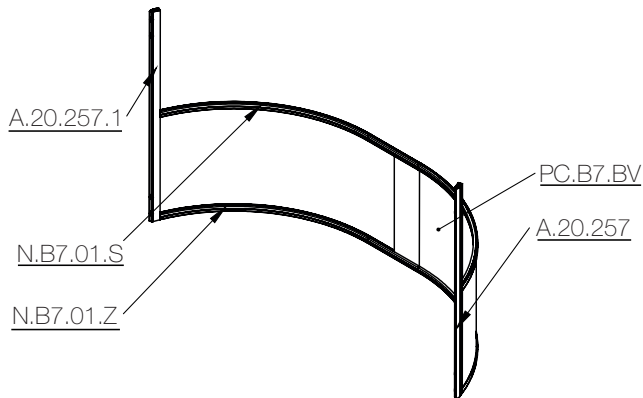

Insert the guide with the drive A.20.257.1 on the sliding door side. Insert the guide A.20.257. Screw all the arches together using screws S.01.

5

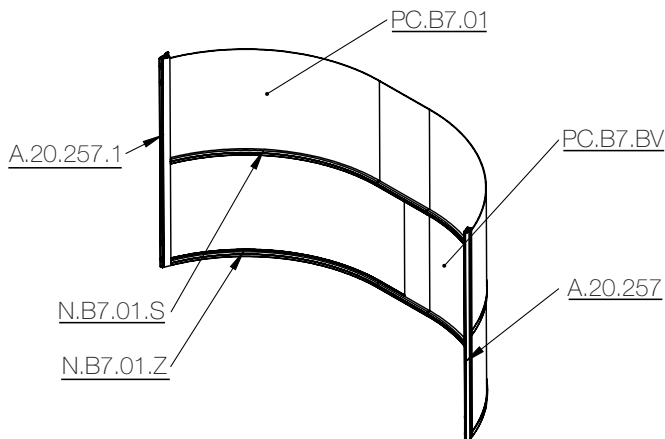

Insert polycarbonate PC.B7.01 into the arch.

6

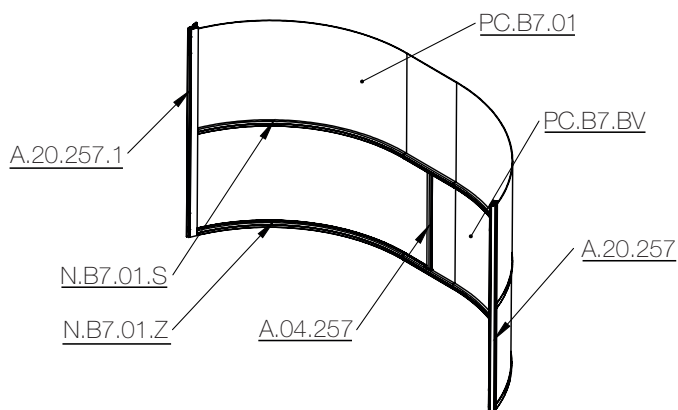

Insert longitudinal reinforcement A.04.257 with the drive and rivet with the arches.

7

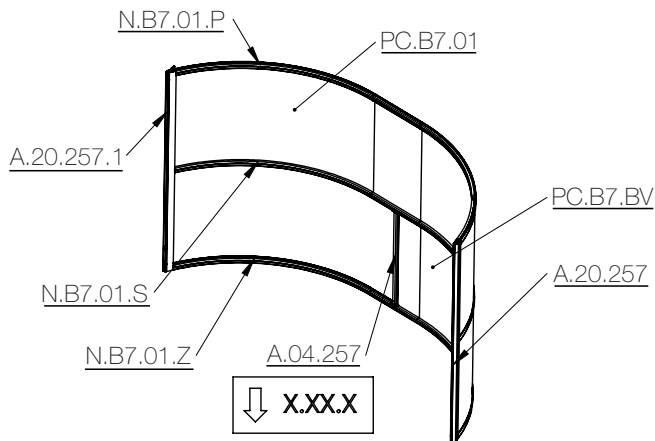

Insert the front arch N.B7.01.P with the arrow pointing downwards. Screw the arch with the guides.

8

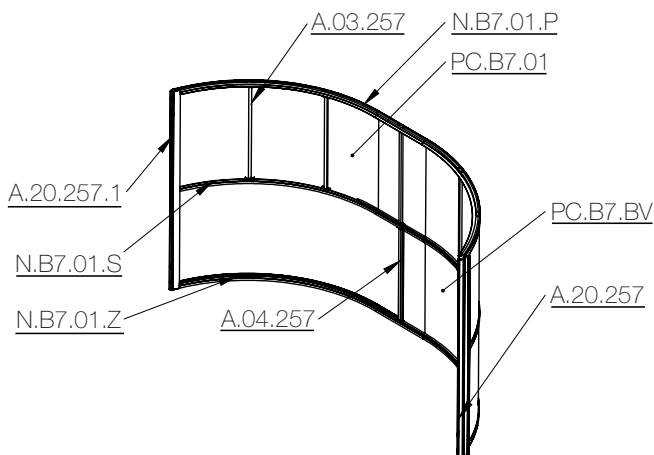

Insert longitudinal reinforcements A.03.257 and rivet them with the arches.



NOTE

The arch and guide are fastened together with S.01 screws. Longitudinal reinforcements are riveted using S.20.1 rivets.

5.5 Segment 1 - Entrance RL.45.1D - Mounting workflow

1

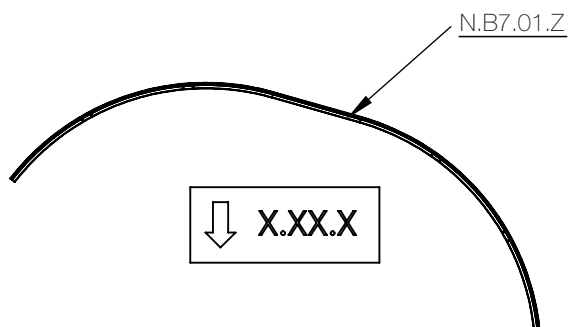

Position the back arch N.B7.01.Z on a flat surface in such a way as to avoid scratching and with the arrow pointing downwards.

2

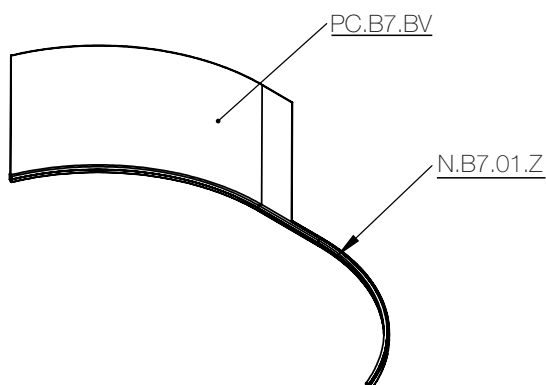

Insert polycarbonate PC.B7.BV correctly according to the placement of the doors.

3

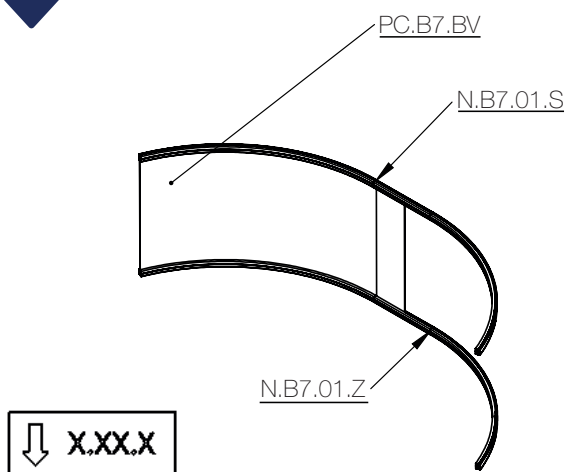

Insert the middle arch on PC.B7.BV with the arrow pointing downwards.

4

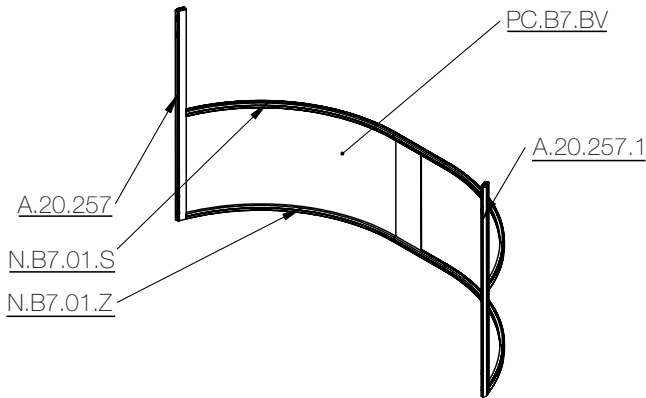

Insert the guide with the drive A.20.257.1 on the sliding door side. Insert the guide A.20.257. Screw all the arches together using screws S.01.

5

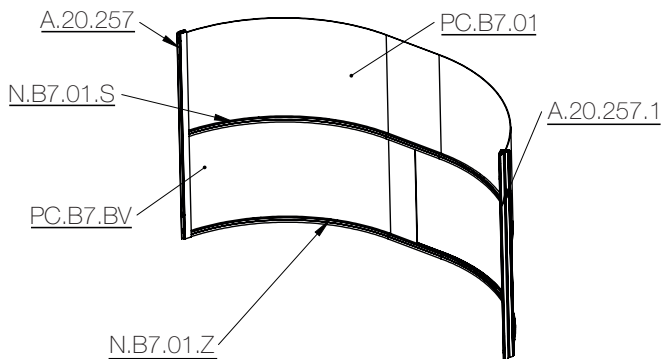

Insert polycarbonate PC.B7.01 into the arch.

6

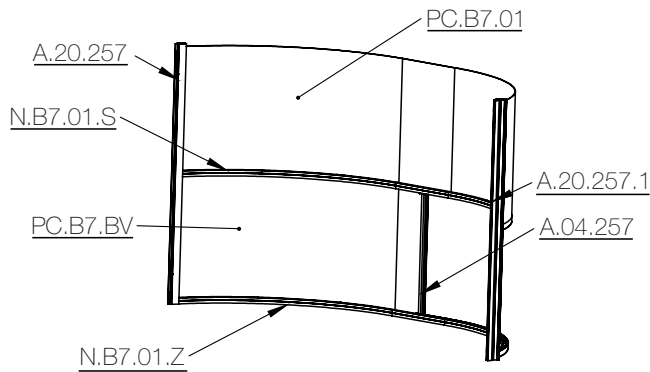

Insert longitudinal reinforcement A.04.257 with the drive and rivet with the arches.

7

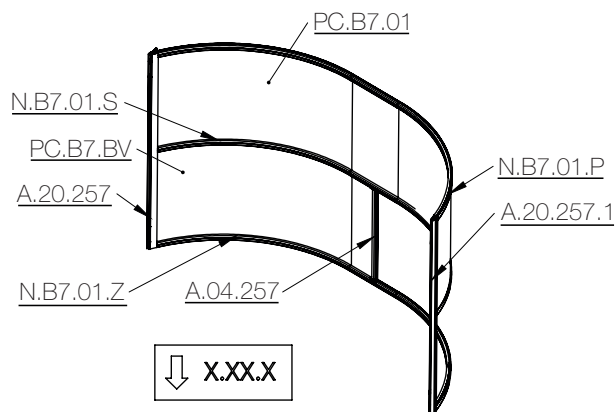

Insert the front arch N.B7.01.P with the arrow pointing downwards. Screw the arch with the guides.

8

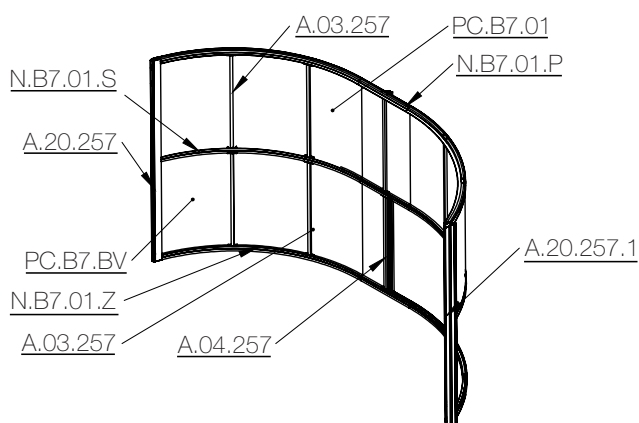

Insert longitudinal reinforcements A.03.257 and rivet them with the arches.



NOTE

The arch and guide are fastened together with S.01 screws. Longitudinal reinforcements are riveted using S.20.1 rivets.

5 Segment 1

5.6 Segment 1 - Rubber seal

Insert the rubber seal around the perimeter of the polycarbonate.

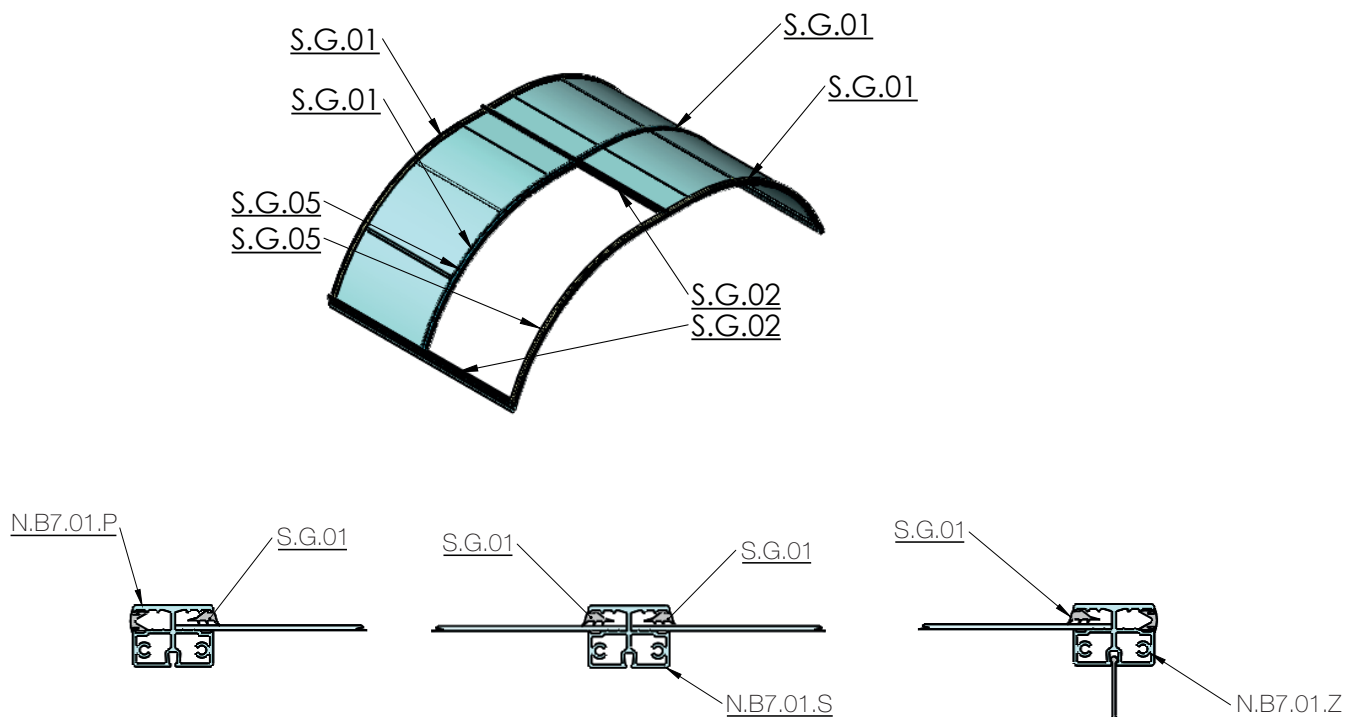

NOTE

After mounting the segment, first attach the plastic caps S.140, end profiles, catchers, collectors, and finally insert the rubber seal.

5.7 Segment 1 - Entrance A,C - Catchers and collectors placement

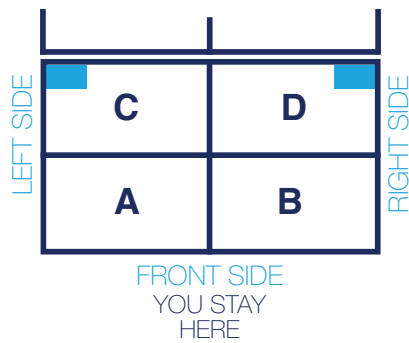

The placement of segment catchers and collectors.
Segment 1
Entrance A, C

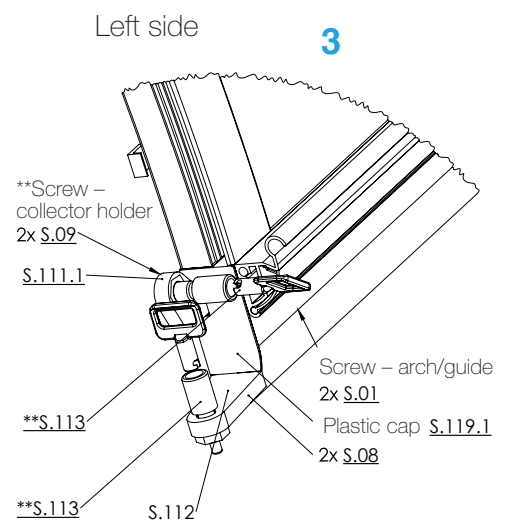
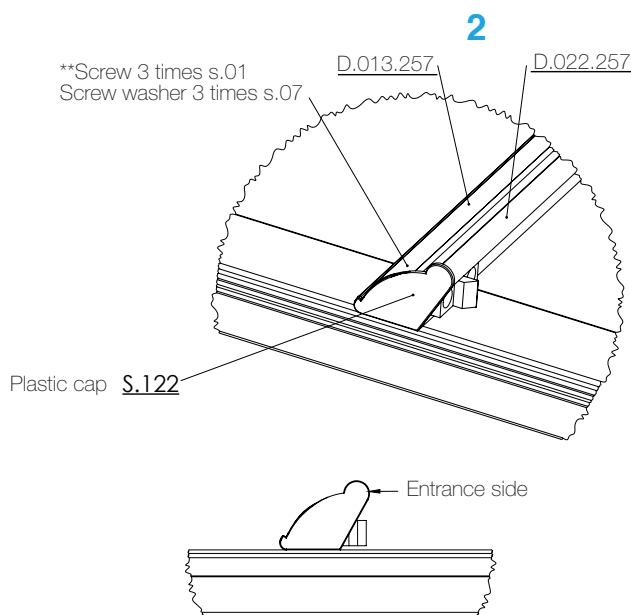
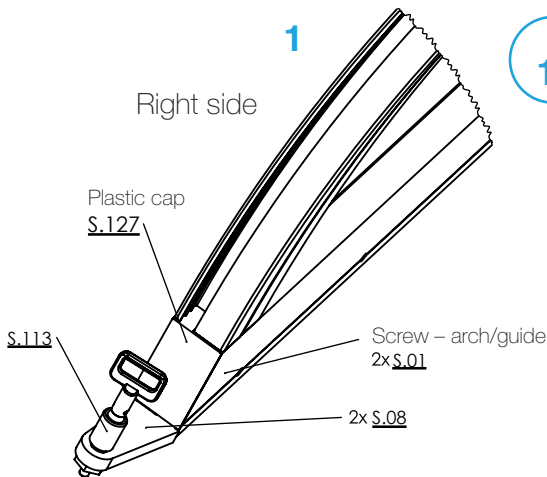
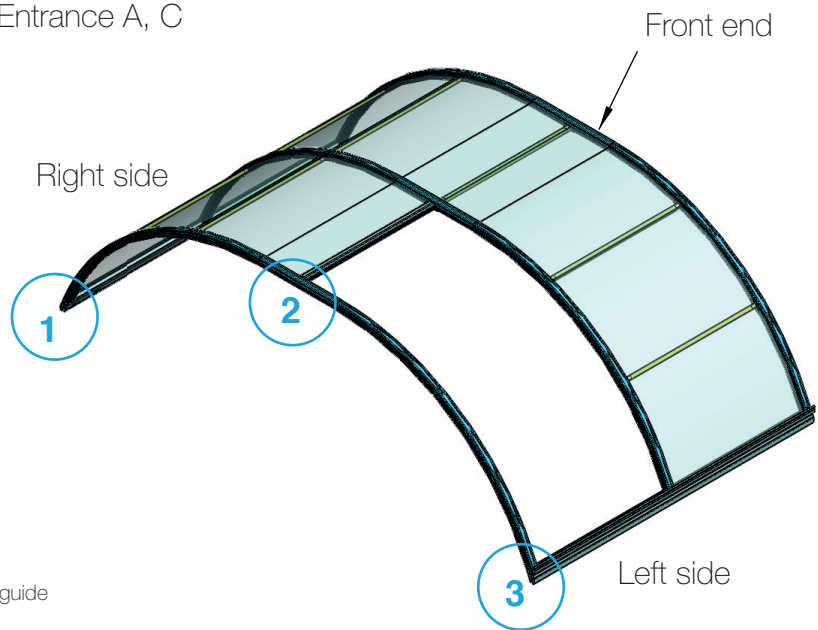

* Pre-drilled

** Adjust before tightening

5.8 Segment 1 - Entrance B, D - Catchers and collectors placement

The placement of segment catchers and collectors.
Segment 1
Entrance B, D

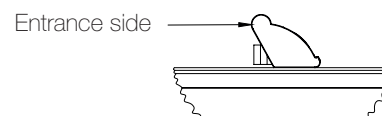
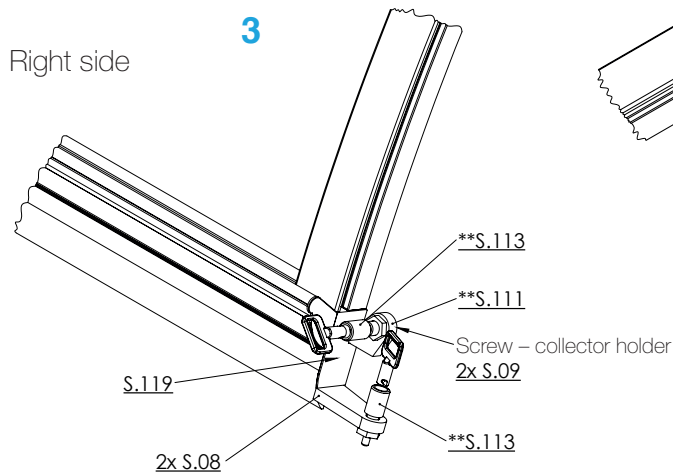
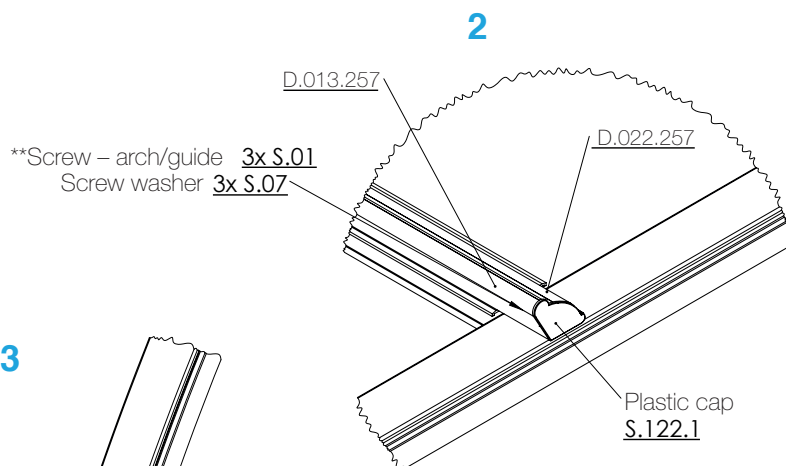
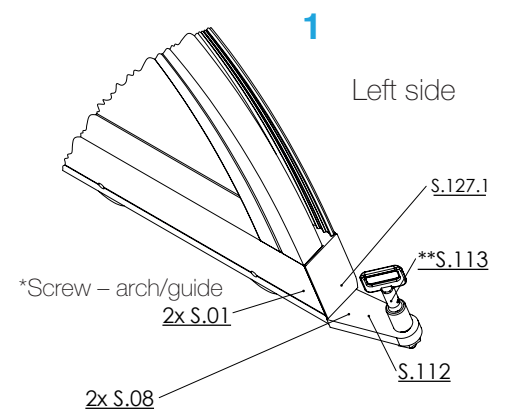
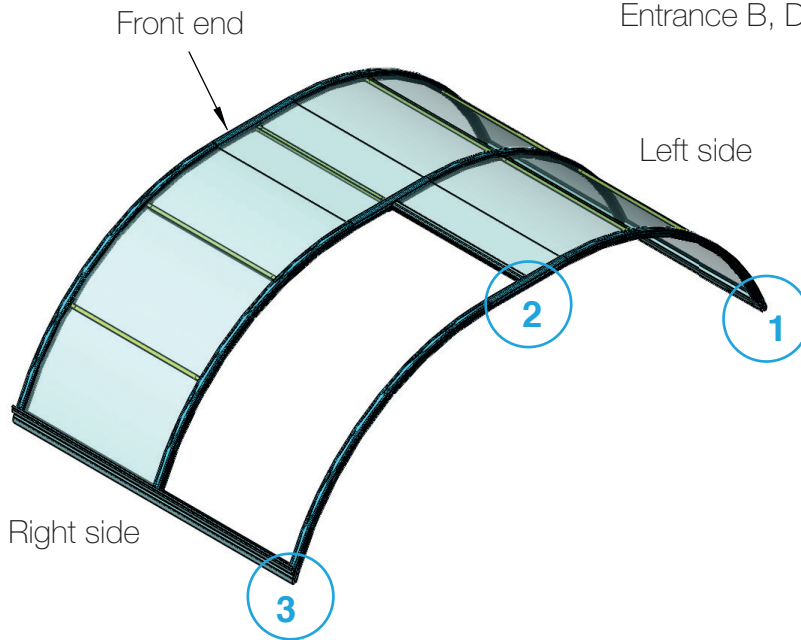
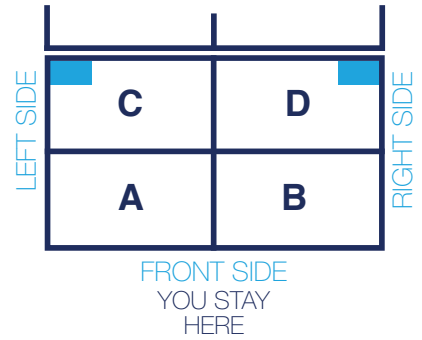

* Pre-drilled
** Adjust before tightening

6 Segments 2, 3, 4

6.1. Parts of the segments 2, 3, 4

Segment 2	Description	Pcs	Segment 3	Description	Pcs	Segment 4	Description	Pcs
N.B7.02.P	Front arch n.1	1	N.B7.03.P	Front arch n.1	1	N.B7.04.P	Front arch n.1	1
N.B7.02.S	Middle arch n.2	1	N.B7.03.S	Middle arch n.2	1	N.B7.04.S	Middle arch n.2	1
N.B7.02.Z	Back arch n.3	1	N.B7.03.Z	Back arch n.3	1	N.B7.04.Z	Back arch n.3	1
A.20.257.L	Guide left	1	A.20.257.L	Guide left	1	A.20.257.L	Guide left	1
A.20.257.P	Guide right	1	A.20.257.P	Guide right	1	A.20.257.P	Guide right	1
PC.B7.02	Polycarbonate, whole arch	2	PC.B7.03	Polycarbonate, whole arch	2	PC.B7.04	Polycarbonate, whole arch	2
A.03.257	Longitudinal reinforcement	14	A.03.257	Longitudinal reinforcement	14	A.03.257	Longitudinal reinforcement	14
S.G.01	Rubber seal		S.G.01	Rubber seal		S.G.01	Rubber seal	

Fasteners	Description	Placing	Pcs
S.01	Screw	Arch/guide	36
S.20.1	Rivet	Arch /reinforcement	168

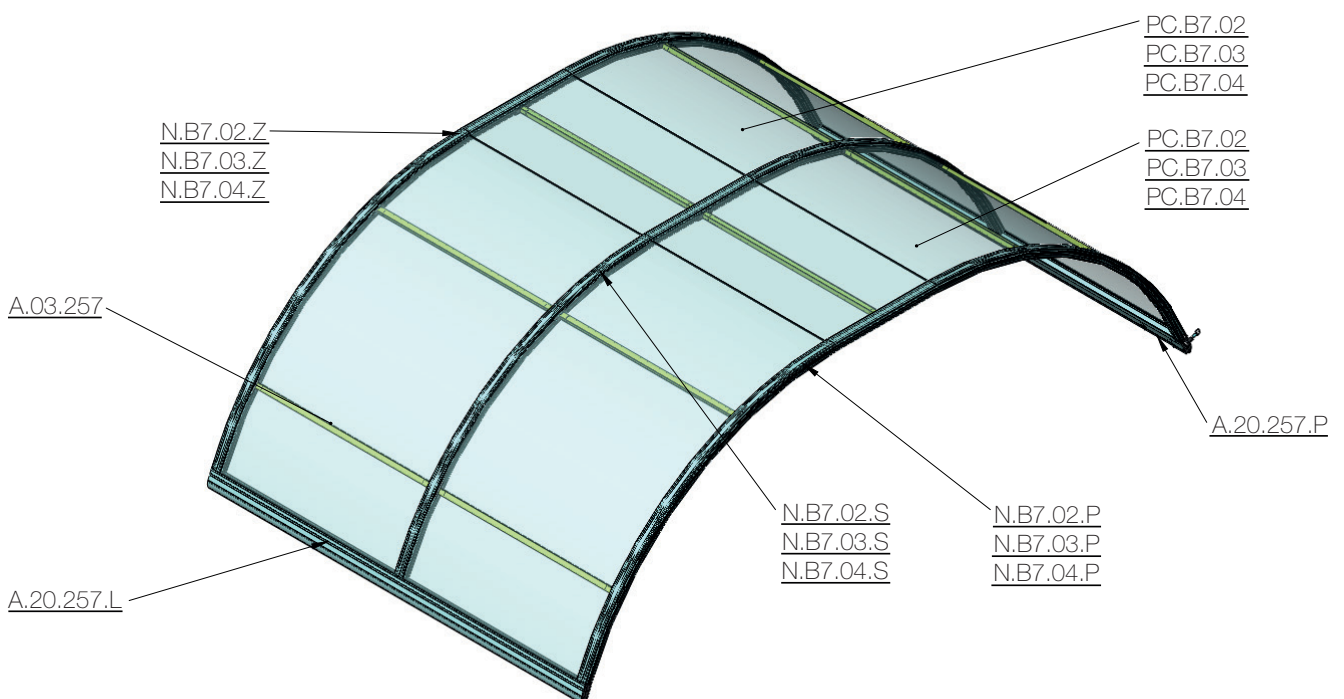

6 Segments 2, 3, 4

6.2 Segments 2, 3, 4 - Mounting workflow

1

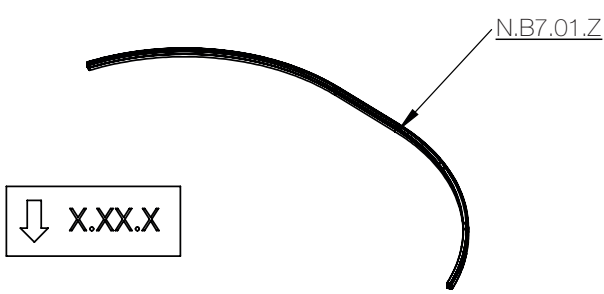

N.B7.01.Z

↓ X.XX.X

Position the back arch N.B7.01.Z on a flat surface in such a way as to avoid scratching and with the arrow pointing downwards.

2

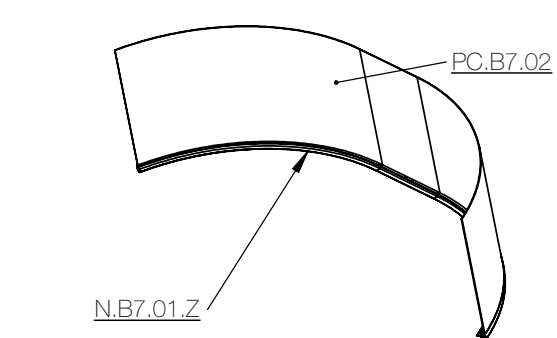

PC.B7.02

N.B7.01.Z

Insert polycarbonate PC.B7.02 into the arch.

3

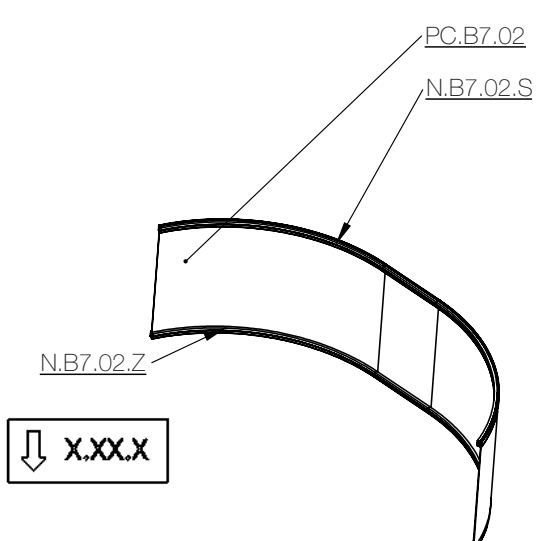

PC.B7.02

N.B7.02.S

N.B7.02.Z

↓ X.XX.X

Insert the middle arch N.B7.01.S on PC.B7.02 with the arrow pointing downwards.

6 Segments 2, 3, 4

4

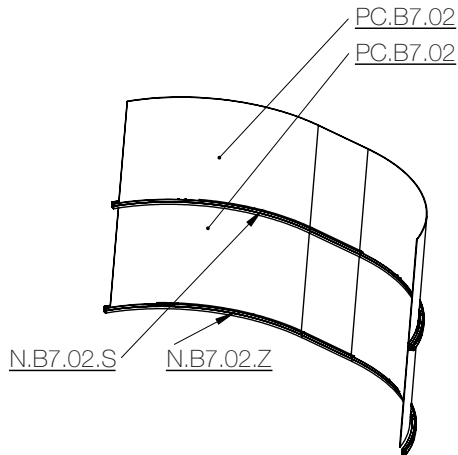

Insert PC.B7.02 into the arch.

5

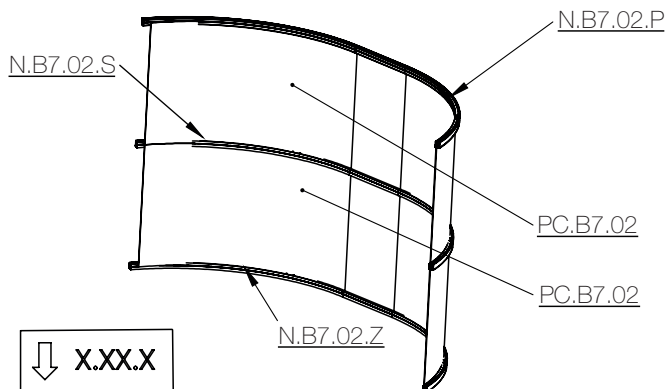

Insert the front arch N.B7.02.P on PC.B7.02 with the arrow pointing downwards.

6

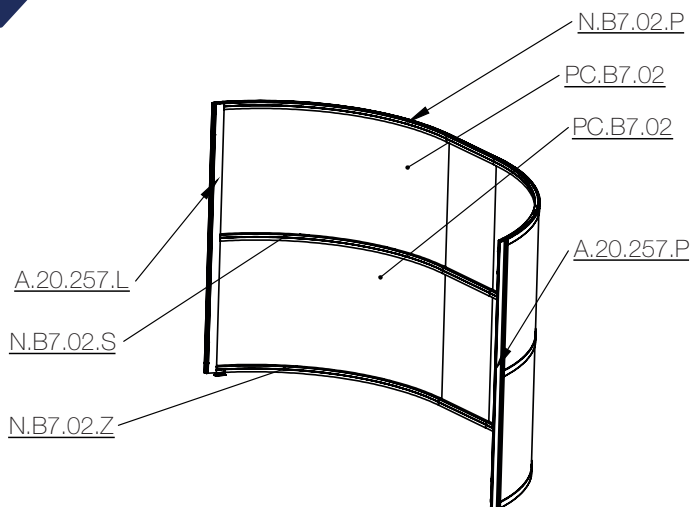

Insert the 2 guides A.20.257.L and A.20.257.P and screw them with the arches.

6 Segments 2, 3, 4

7

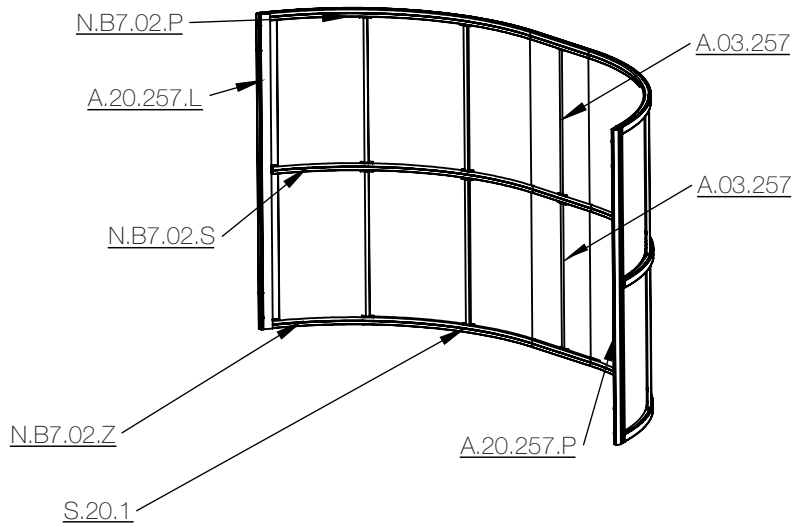

Insert longitudinal reinforcements A.03.257 and rivet them.

8

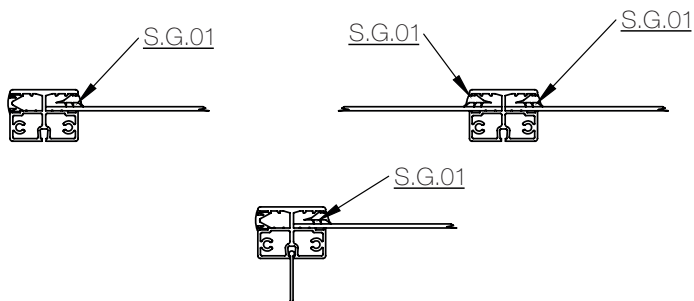

Insert the rubber seal S.G.01 around the perimeter of the polycarbonate.



NOTE

The arch and guide are fastened together with S.01 screws. Longitudinal reinforcements are riveted using S.20.1 rivets. After mounting the segment, attach the plastic caps.

6 Segments 2, 3, 4

6.3 Middle segments 2, 3 - Collectors



NOTE
The segment collectors are always placed on the side of the side door entrance.

The placement of segment collector.

Segment 2, 3
Entrance A, C

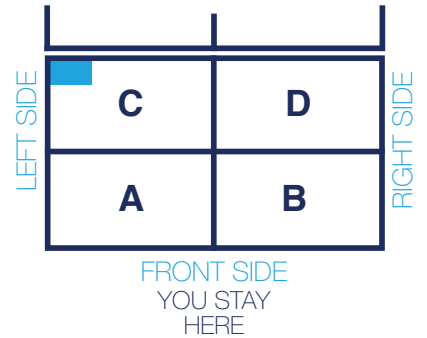

The placement of segment collector.

Segment 2, 3
Entrance B, D

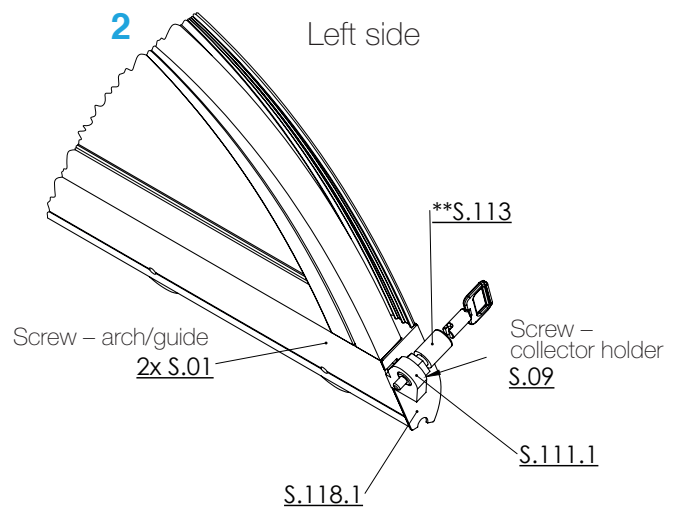
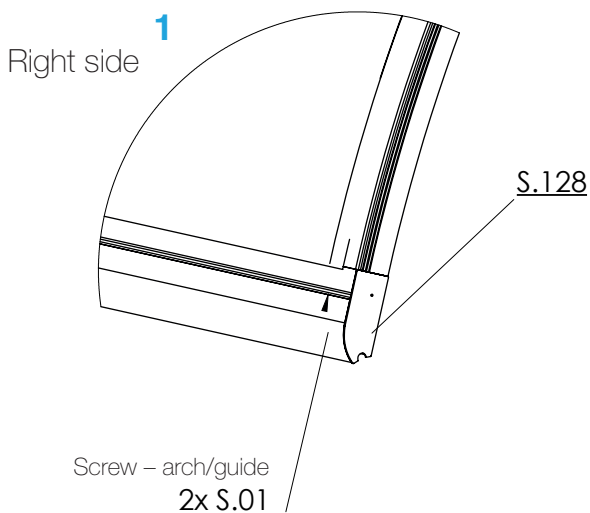
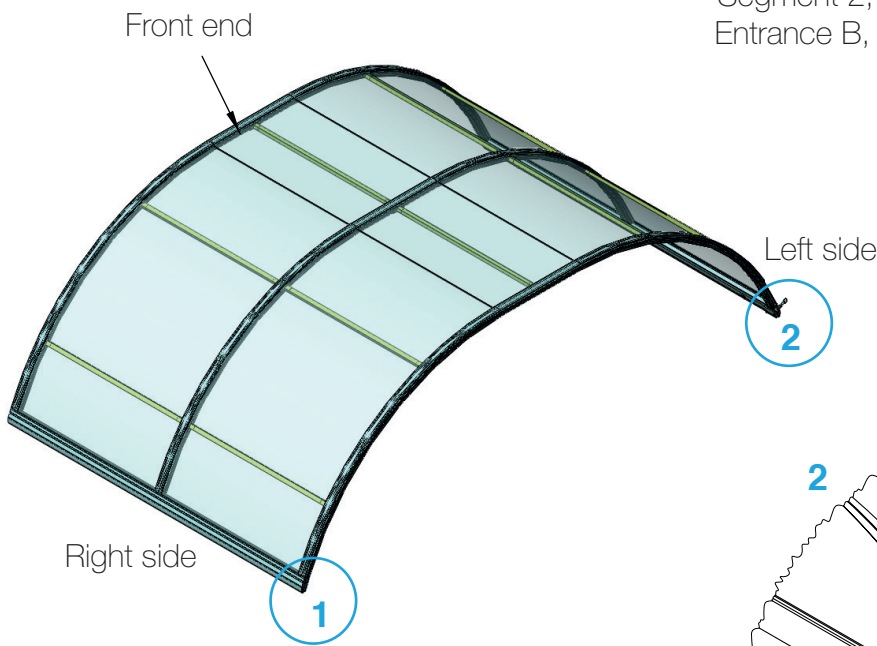
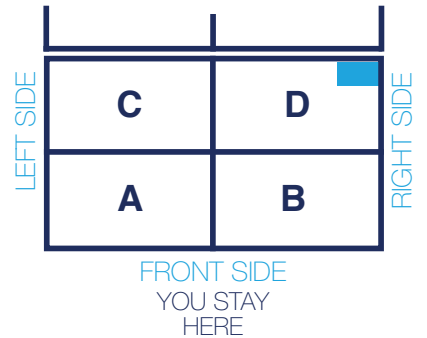

* Pre-drilled

** Adjust before tightening

6 Segments 2, 3, 4

6.4 Last segment 4 - Catchers

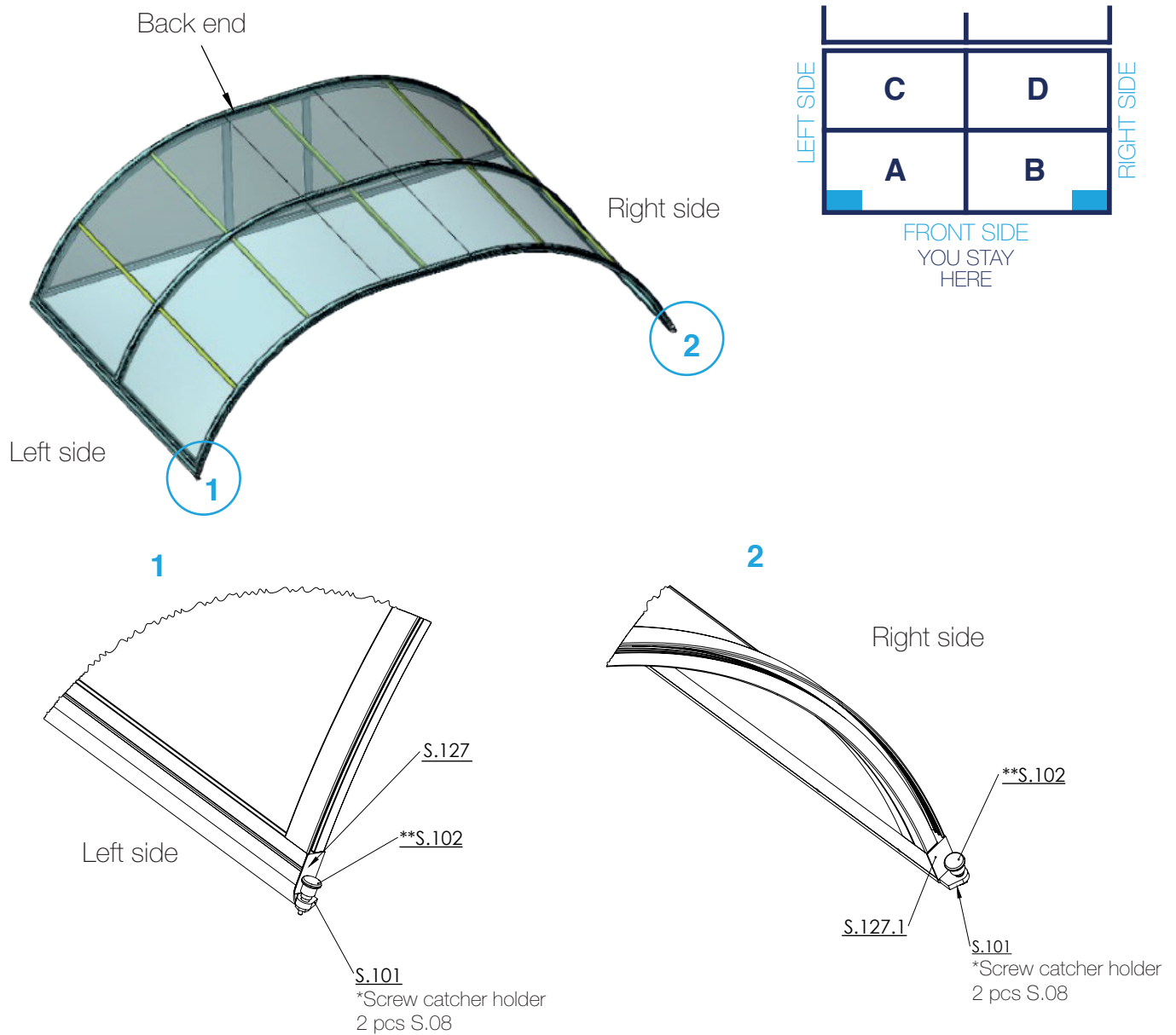

* Pre-drilled
** Adjust before tightening

7 Front and back ends

Front and back ends are always mounted after the corresponding segment has been installed on the track.

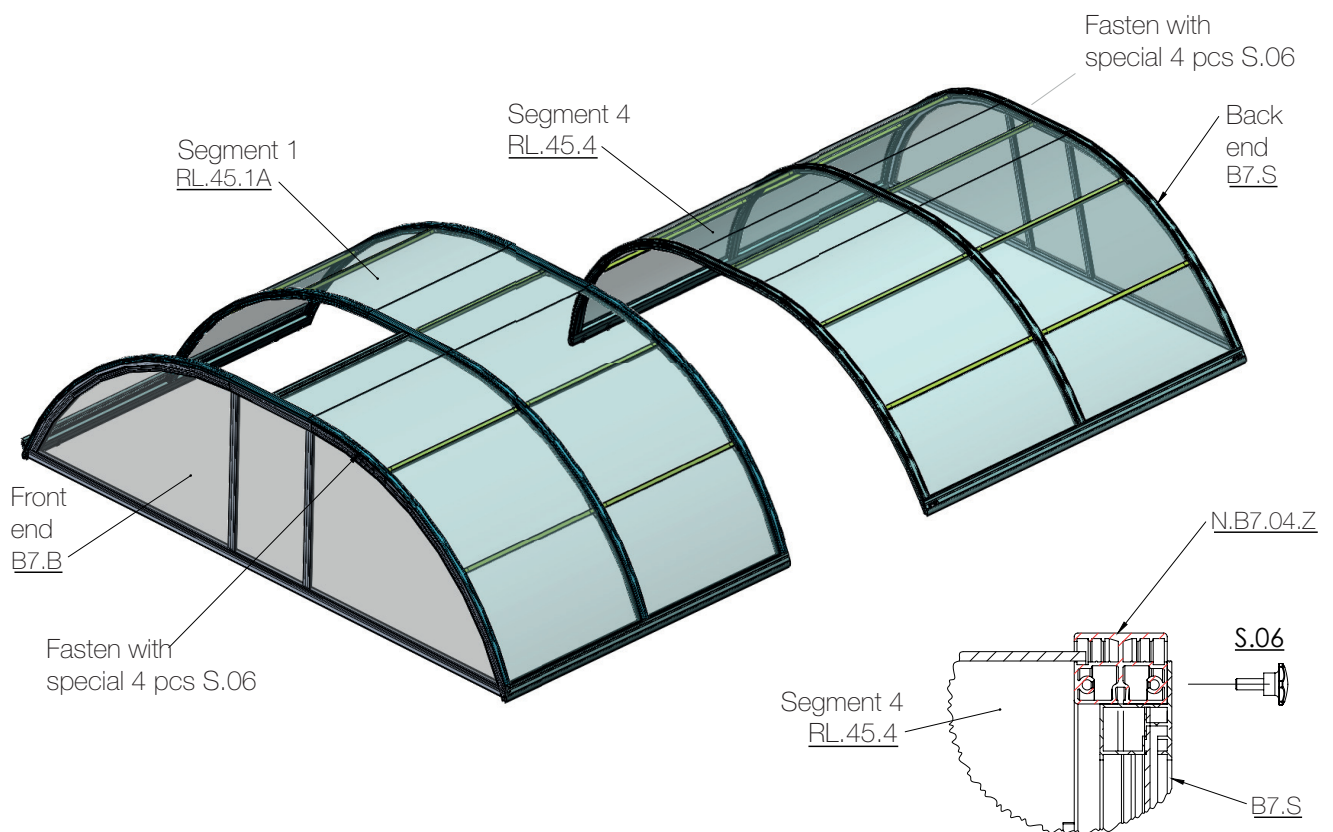

NOTE

Ends Assembly

Position the end B7.B and after the end B7.S against the threaded holes on the surface of the arch.

Mount the front and back ends of the segment by screwing them using the special large Diamant screws S.06.

8 Entrance - side sliding door

8.1 Entrance - Side sliding door - Parts of the side sliding door

Code	Description	Pcs
V.B7.P	Arch	1
V.B7.Z	Arch	1
V.01.P.L	Guide	2
PC.B7.D	Polycarbonate	1
A.03.257	Longitudinal reinforcement	3
S.G.01	Rubber seal	
S.114	Door lock	1
S.109	Door handle	1

Fasteners	Description	Placing	Pcs
S.01	Screw	Arch / guide / door handle	10
S.20.1	Rivet	Arch / longitudinal reinforcement	12
S.02	Screw	Arch / door handle	2
S.23	Rivet	Catcher / guide	4

After installing the door lock, adjust the dowel pin to the correct height by cutting.

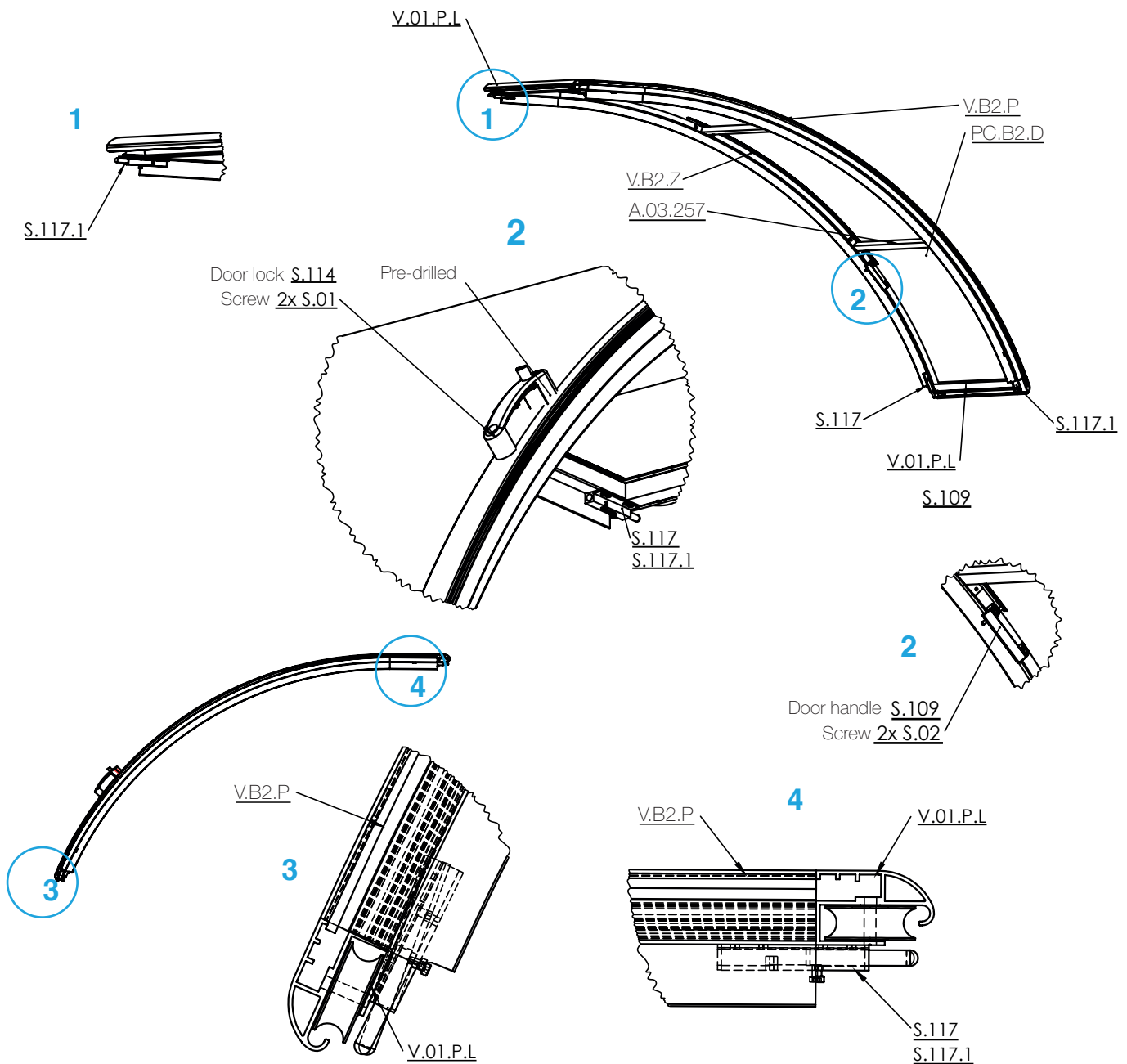

8 Entrance - side sliding door

8.2 Entrance - Side sliding door - Mounting workflow

1

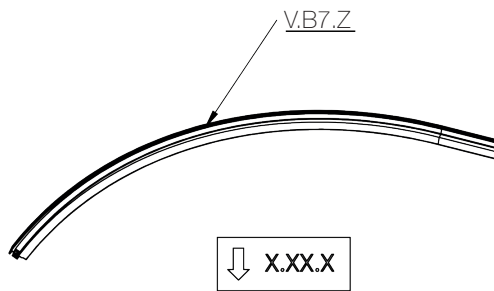

Position the back arch V.B7.Z on a flat surface in such a way as to avoid scratching and with the arrow pointing downwards.

2

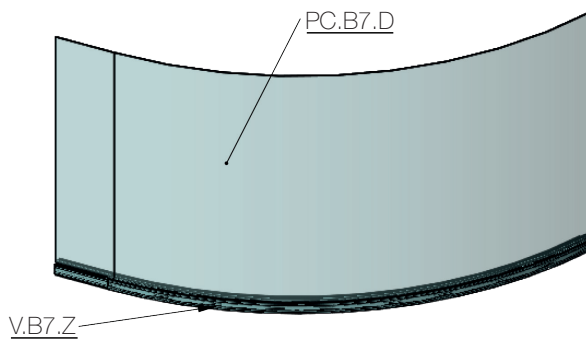

Insert polycarbonate PC.B7.D into the arch.

3

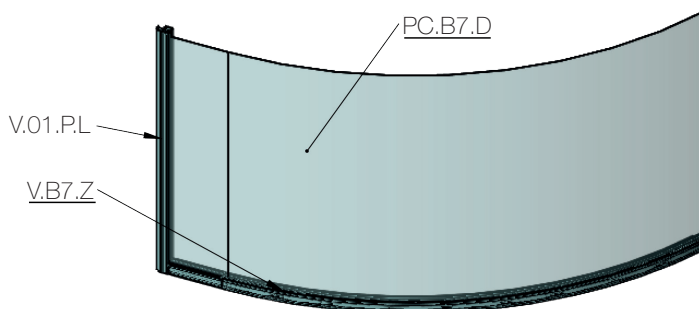

Insert the guide V.01.P.L and screw it with the back arch V.B7.Z.

8 Entrance - side sliding door

4

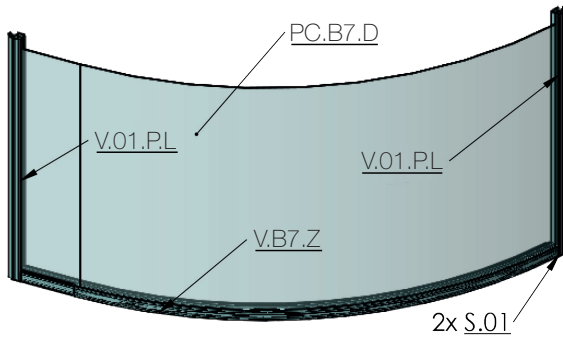

Insert the second guide V.01.PL and screw it with the back arch V.B7.Z.

5

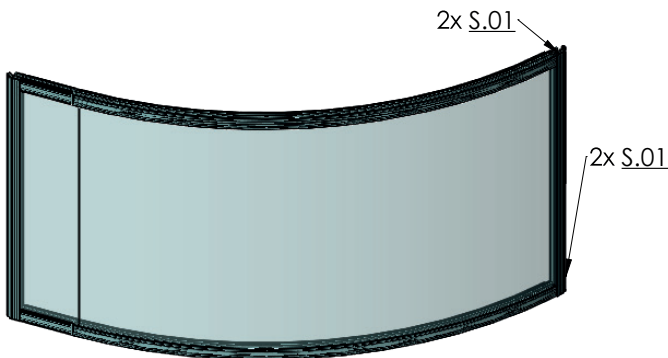

Insert the front arch V.B7.P on PC.B7.D with the arrow pointing downwards and screw it with the guide V.01.PL.

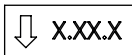

6

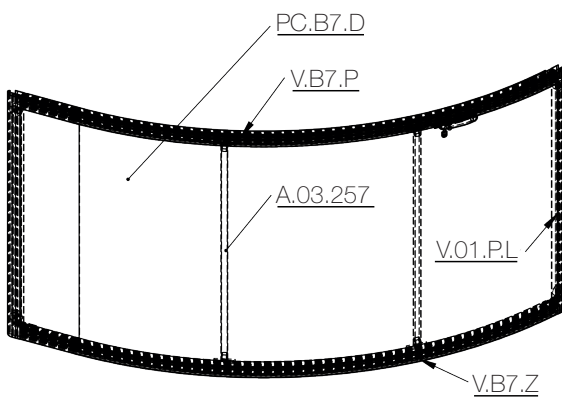

Insert longitudinal reinforcements A.03.257 and rivet them with the arches.

8 Entrance - side sliding door

7

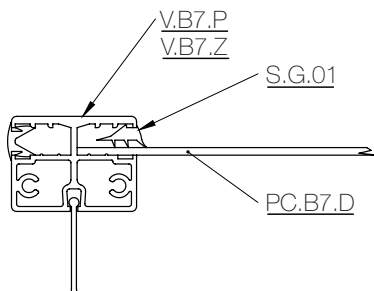

Insert the rubber seal S.G.01 around the perimeter of the polycarbonate.

8

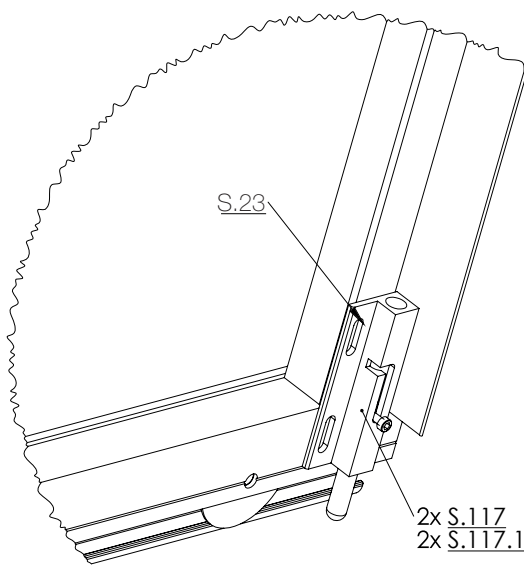

Pre-assembled.
Rivet with 4 pcs S.23.



NOTE

After mounting the entrance, attach the plastic caps S.116 and S.140.

8 Entrance - side sliding door

8.3 Entrance - Side sliding door - Installation

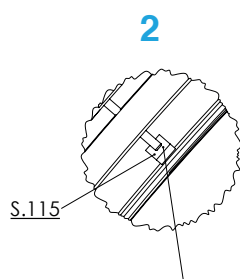
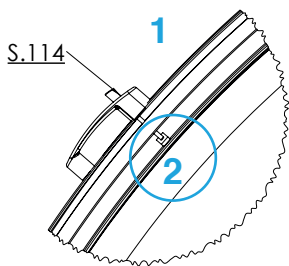
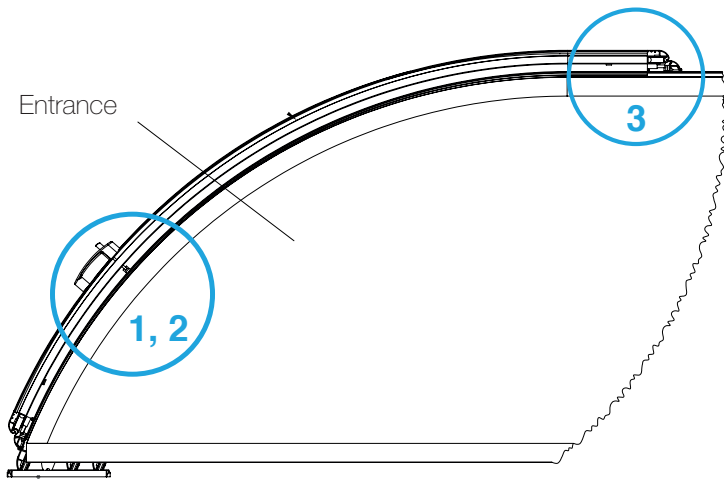



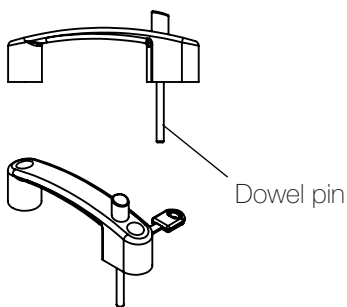
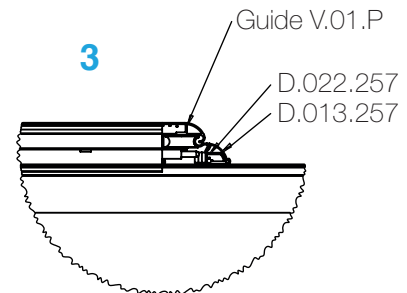



Trim the dowel pin to fit within a maximum tolerance of 1-2mm.

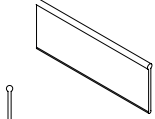
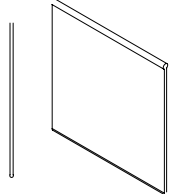
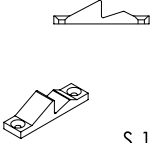
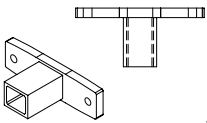

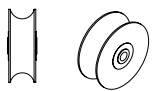
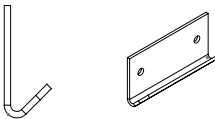
After installing the door lock, adjust the dowel pin to the correct height by cutting.

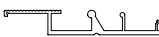
9 Spare parts

 <p>S.G.03</p>	 <p>S.G.04</p>	 <p>S.103</p>	 <p>S.105</p>
 <p>S.106</p>	 <p>S.107</p>	 <p>S.108</p>	 <p>S.115</p>
 <p>D.008-</p>		 <p>D.017-</p>	 <p>D.012-</p>



www.diamant-unipool.eu/en/docs/manuals

Diamant Unipool, s. r. o.
Bynina 186
757 01 Valašské Meziříčí

Tel.: 571 752 111
E-mail: info@bazenydiamant.cz
www.diamant-unipool.eu

A3/EN/BOX7/202312/V.01